

Collins

INSTRUCTION BOOK

AM BROADCAST TRANSMITTER

20V-2

Parts from Cont. Electronics

Parts Dept. 1-214-327-4532

Cont. Main Number 1-214-381-7161

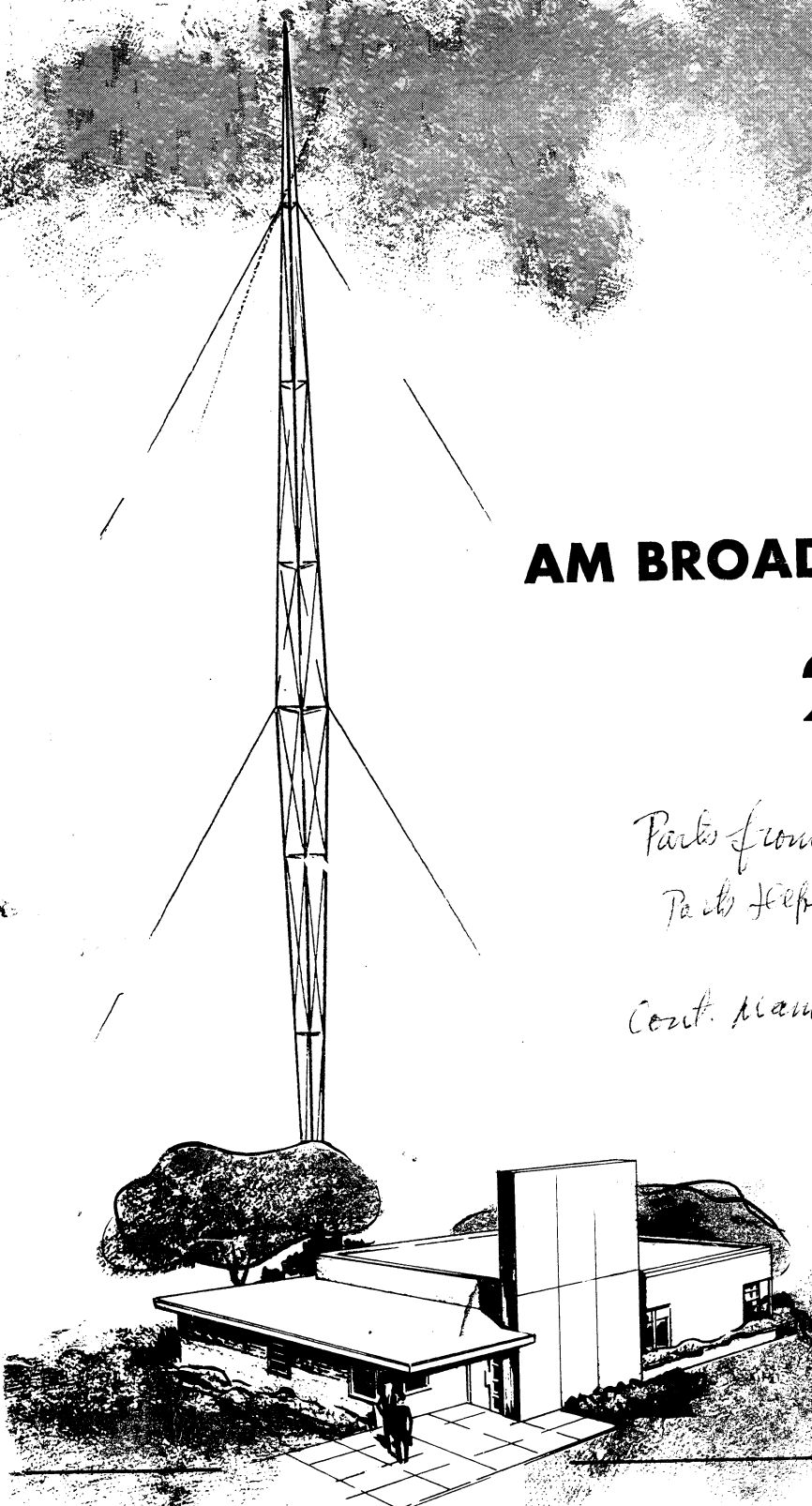

COLLINS RADIO COMPANY

GUARANTEE

The equipment described herein is sold under the following guarantee:

Collins agrees to repair or replace, without charge, any equipment, parts, or accessories which are defective as to design, workmanship or material, and which are returned to Collins at its factory, transportation prepaid, provided

- (a) Notice of the claimed defect is given Collins within one (1) year from date of delivery and goods are returned in accordance with Collins' instructions.
- (b) Equipment, accessories, tubes, and batteries not manufactured by Collins or from Collins' designs are subject to only such adjustments as Collins may obtain from the supplier thereof.
- (c) No equipment or accessory shall be deemed to be defective if, due to exposure or excessive moisture in the atmosphere or otherwise after delivery, it shall fail to operate in a normal or proper manner.

Collins further guarantees that any radio transmitter described herein will deliver full radio frequency power output at the antenna lead when connected to a suitable load, but such guarantee shall not be construed as a guarantee of any definite coverage or range of said apparatus.

The guarantee of these paragraphs is void if equipment is altered or repaired by others than Collins or its authorized service center.

No other warranties, expressed or implied, shall be applicable to any equipment sold hereunder, and the foregoing shall constitute the Buyer's sole right and remedy under the agreements in this paragraph contained. In no event shall Collins have any liability for consequential damages, or for loss, damage or expense directly or indirectly arising from the use of the products, or any inability to use them either separately or in combination with other equipment or materials, or from any other cause.

HOW TO RETURN MATERIAL OR EQUIPMENT. If, for any reason, you should wish to return material or equipment, whether under the guarantee or otherwise, you should notify us, giving full particulars including the details listed below, insofar as applicable. If the item is thought to be defective, such notice must give full information as to nature of defect and identification (including part number if possible) of part considered defective. (With respect to tubes we suggest that your adjustments can be speeded up if you give notice of defect directly to the tube manufacturer.) Upon receipt of such notice, Collins will promptly advise you respecting the return. Failure to secure our advice prior to the forwarding of the goods or failure to provide full particulars may cause unnecessary delay in handling of your returned merchandise.

ADDRESS:

Collins Radio Company
Sales Service Department
Cedar Rapids, Iowa

INFORMATION NEEDED:

- (A) Type number, name, and serial number of equipment
- (B) Date of delivery of equipment
- (C) Date placed in service
- (D) Number of hours of service
- (E) Nature of trouble
- (F) Cause of trouble if known
- (G) Part number (9 or 10 digit number) and name of part thought to be causing trouble
- (H) Item or symbol number of same obtained from parts list or schematic
- (I) Collins' number (and name) of unit sub-assemblies involved in trouble
- (J) Remarks

HOW TO ORDER REPLACEMENT PARTS.

When ordering replacement parts, you should direct your order as indicated below and furnish the following information insofar as applicable. To enable us to give you better replacement service, please be sure to give us complete information.

ADDRESS:

Collins Radio Company
Sales Service Department
Cedar Rapids, Iowa

INFORMATION NEEDED:

- (A) Quantity required
- (B) Collins' part number (9 or 10 digit number) and description
- (C) Item or symbol number obtained from parts list or schematic
- (D) Collins' type number, name, and serial number of principal equipment
- (E) Unit sub-assembly number (where applicable)

*Transmitter on air for field intensity measurements
Sat. Sept. 8, 1962*

AM
BROADCAST TRANSMITTER
20V-2

INSTRUCTION BOOK

6th EDITION, 15 MARCH 1961

520-5030-00

© COLLINS RADIO COMPANY
1957, 1959, 1961

CEDAR RAPIDS, IOWA, U.S.A.

PRINTED IN THE UNITED STATES OF AMERICA



TABLE OF CONTENTS

SECTION 1 - GENERAL DESCRIPTION

	Page
1.1. General	1-1
1.2. General Description of R-F Section.	1-2
1.3. General Description of Audio Section.	1-2
1.4. General Description of Power Supplies	1-3

SECTION 2 - INSTALLATION

2.1. Unpacking	2-1
2.2. Location of the Transmitter	2-1
2.3. Replacement of Units Removed for Shipping	2-1
2.4. Power Input Connections	2-2
2.5. Audio Input Connections	2-3
2.6. R-F Output Connections.	2-3
2.7. Frequency Monitor Connections	2-3
2.8. Modulation Monitor Connections.	2-3
2.9. Audio Monitor Connections	2-3
2.10. Inter-Unit Cabling Diagram.	2-3
2.11. Control Circuit Connections	2-6
2.12. Arc Gaps.	2-6

SECTION 3 - OPERATION

3.1. Filament Control.	3-1
3.2. Time Delay.	3-1
3.3. Plate Control	3-1
3.4. Automatic Sequence Starting	3-2
3.5. Crystal Selector Switch	3-2
3.6. Crystal Frequency Trimmer Controls.	3-2
3.7. Multimeter Switch	3-2
3.8. First R-F Buffer Tank Circuit Trimmers.	3-2
3.9. R-F Driver Tank Trimmers.	3-3
3.10. Power Amplifier Plate Tuning and Loading Controls	3-3
3.11. Power Change Switch	3-3
3.12. PA Drive Control.	3-3
3.13. Audio Hum Controls.	3-4
3.14. Modulator Bias Adjustments.	3-4
3.15. Arc-Suppression Circuit	3-4
3.16. Starting the Equipment in a New Installation.	3-5
3.17. Adjustment of Audio Section	3-7
3.18. Overload Relay Adjustment	3-7
3.19. Starting in Normal Operation.	3-7

SECTION 4 - MAINTENANCE

	Page
4.1. Routine Maintenance	4-0
4.2. Trouble Shooting	4-1
4.3. Ordering Replacement Parts	4-1

SECTION 5 - PARTS LIST

SECTION 6 - ILLUSTRATIONS

SECTION 7 - LINE DRAWINGS

LIST OF TABLES

Table		Page
1-1	20V-2 Transmitter Specifications	1-3
1-2	Tube Complement	1-4
2-1	List of Wire Types	2-5
2-2	List of Wire Sizes and Color Codes	2-5
2-3	Approximate Output Tank Tuning Data	2-7
4-1	Typical Meter Readings	4-2
4-2	Typical Voltages and Currents	4-3
4-3	Primary Power Input	4-4

LIST OF ILLUSTRATIONS

Figure No.	Title	Page
1-1	Collins 20V-2 1000/500/250 Watt AM Transmitter.	v
1-2	Collins 20V-2 Transmitter, Rear View.	1-0
2-1	Inter-Unit Cabling Example.	2-4
6-1	Transmitter Parts Arrangement, Front View	6-1
6-2	Transmitter Parts Arrangement, Rear View.	6-2
6-3	R-F Chassis Parts Arrangement	6-3
6-4	R-F Chassis Parts Arrangement, Bottom View.	6-4
6-5	Audio Chassis Parts Arrangement	6-5
6-6	Audio Chassis Parts Arrangement, Bottom View.	6-6
6-7	Output Network Parts Arrangement, Bottom View	6-7
6-8	Power Supply Chassis Parts Arrangement.	6-8
6-9	Rear Panel Parts Arrangement.	6-9
6-10	Relay Panel Controls.	6-9
6-11	Location of Controls and Instruments.	6-10
7-1	Primary Control Circuit Simplified Schematic.	7-1
7-2	T-102 and T-103 Internal Connections.	7-2
7-3	Arc-Suppression Circuit Simplified Schematic.	7-3
7-4	Transformer Details	7-4
7-5	Typical Installation Diagram.	7-5
7-6	Inter-Unit Cabling Diagram.7-7/7-8
7-7	Main Schematic.7-9/7-10

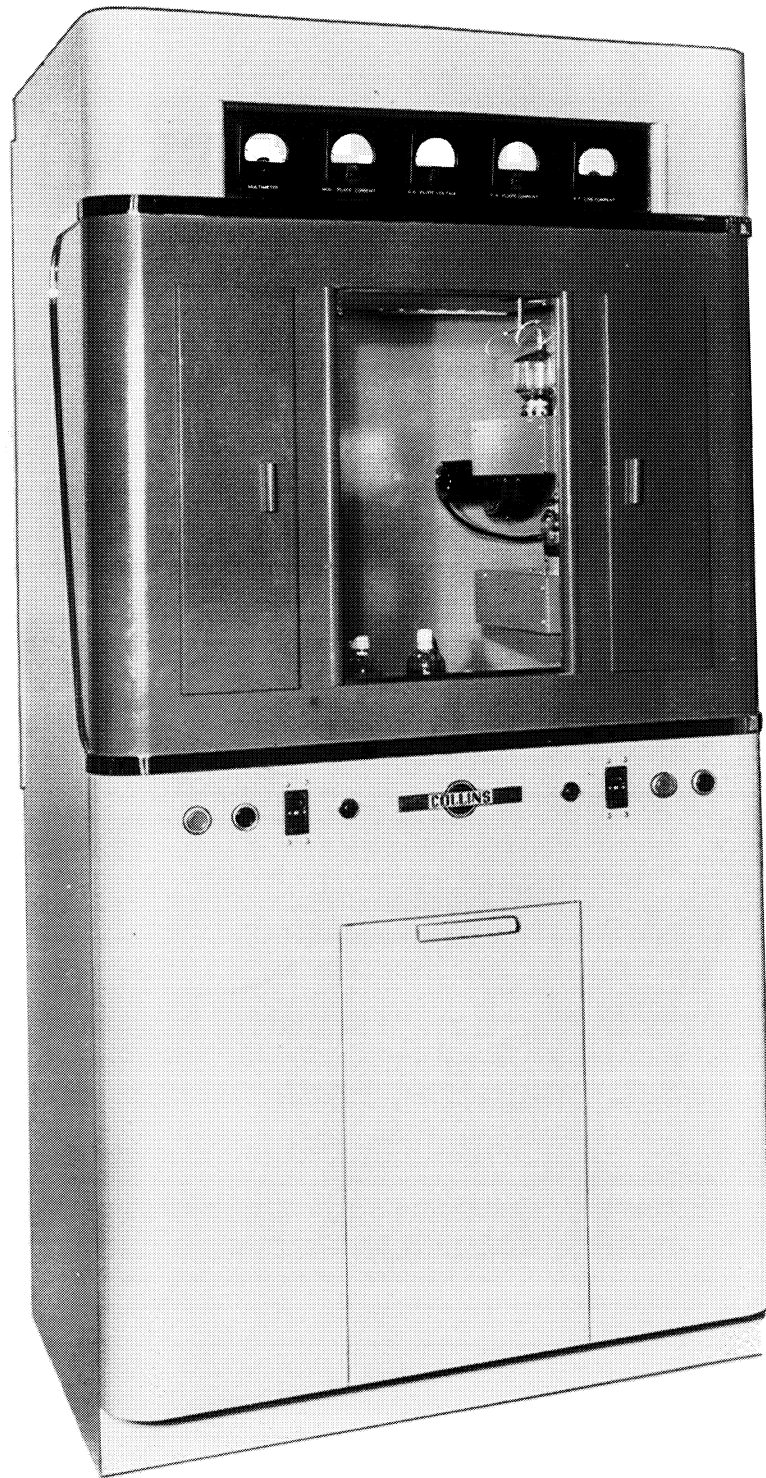

Figure 1-1. Collins 20V-2 1000/500/250 Watt AM Transmitter

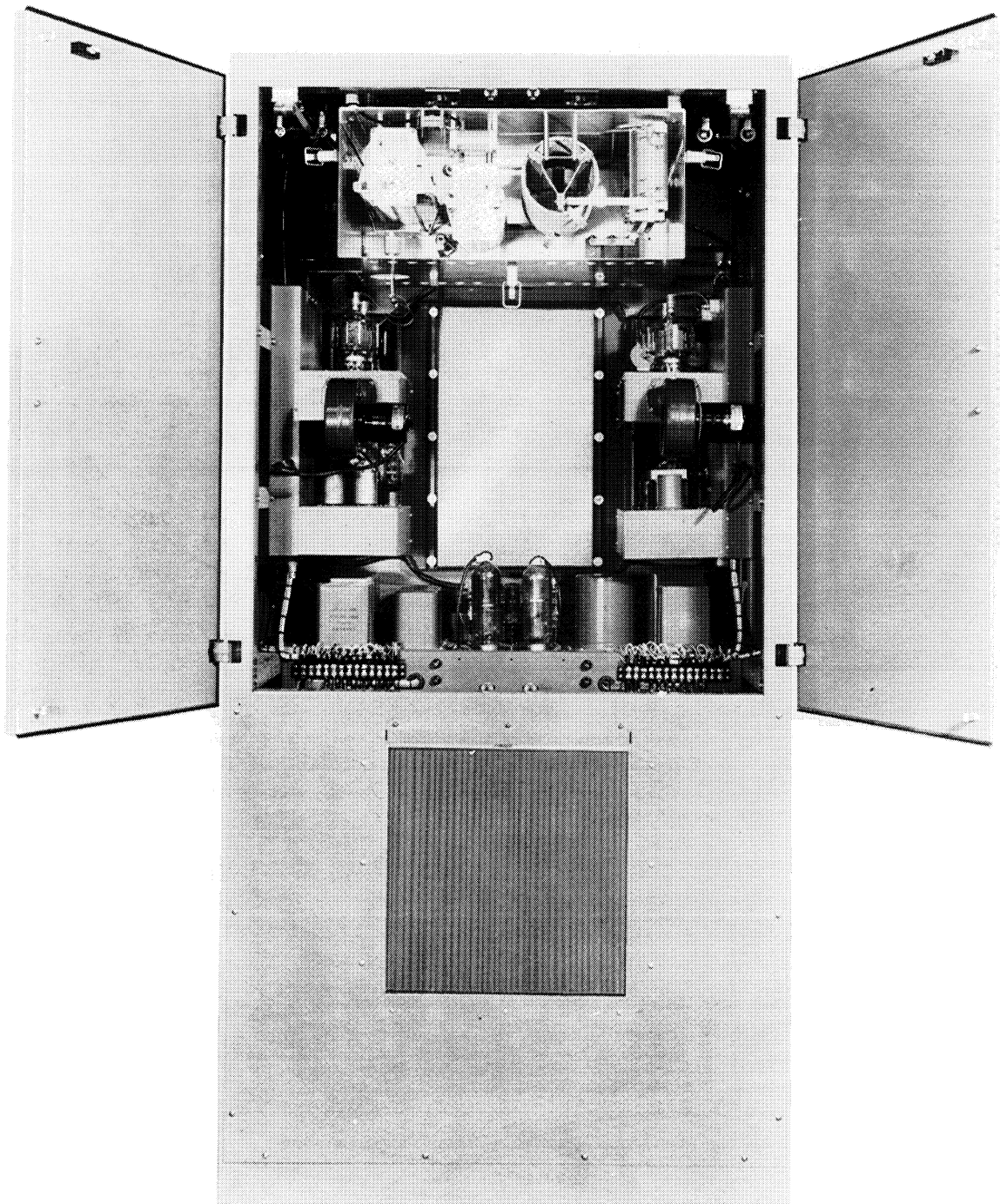

Figure 1-2. Collins 20V-2 Transmitter, Rear View

SECTION 1 GENERAL DESCRIPTION

1.1. GENERAL

The Collins type 20V-2 1000/500/250 watt AM transmitter has been designed for high-fidelity broadcast service. Advanced engineering techniques and new high-quality components have combined to produce a transmitter that provides outstanding features designed to meet today's demand for better service from modern broadcast equipment.

One neatly-styled heavy-gauge sheet metal cabinet houses the entire transmitter. The complete equipment occupies a space 27" deep by 38" wide by 76" high. Its weight is approximately 1150 pounds. Transformers and other heavy units are mounted on the cabinet floor. R-f and audio stages are housed in separate chassis that are designed for ease of servicing and maintenance. These two chassis are mounted on the right and left sides respectively, as viewed from the front of the cabinet. The power amplifier plate circuit and r-f output network are housed in a single shielded compartment that is suspended from the roof of the transmitter cabinet. The entire back panel of this r-f compartment is easily removable, providing ready access to the components within. A shelf extending the width of the cabinet holds the rectifier tubes and small transformers. All tubes are easily visible through the large window.

A small removable panel on the lower front of the transmitter allows access to power input terminals and control relays. The large doors at the rear of the cabinet allow access to the upper part of the transmitter for servicing and maintenance. The rear lower half of the transmitter is covered by a removable panel which contains the permanent-type air filter.

All meters are mounted on a single illuminated panel. Their location allows operation of tuning controls while observing meter indications. The four bolts which secure the meter panel fit into slotted holes that allow the panel to be tilted to the desired angle.

Operating controls are conveniently located on the front of the cabinet. Circuit breakers and filament and plate switches are mounted on the left and right sides of the cabinet below the front window. Other controls and switches are mounted behind small vertical access doors located on each side of the front window. As shown in figure 6-11, the right-hand door provides access to the crystal-selector switch, the crystal-frequency trimmers, the audio hum control, the PA drive control, the r-f driver tank trimmers, the first buffer tank trimmers, the power amplifier tuning control, and the power amplifier loading control. The latter two control position the tuning capacitor and loading capacitor by means of flexible drive shaft assemblies. Access to the multimeter switch, the power change switch, the modulator bias adjustments, and the other audio hum control is provided through the left-hand door.

Ventilating air is drawn through a cleanable bronze air filter by a low speed, high volume fan. The air cools the entire transmitter and is exhausted through a shielded opening in the roof of the cabinet. Individual blowers supply air directly to R-F Final and Modulator tubes.

The description and function of each part is included in the parts list in Section 5 of this book. section 3, Operation, lists the function of all controls.

1.2. GENERAL DESCRIPTION OF R-F SECTION

As a result of major advances in crystal stability and oscillator design, the crystal oven and its associated thermostats, relays and other controls have been eliminated. A highly-perfected oscillator design in conjunction with extremely stable, low-temperature-coefficient crystals has resulted in exceptionally good frequency stability. There are provisions for mounting two crystals on the r-f chassis, with one of the two always available in standby position. Crystals are easily selected by means of the crystal switch located behind the right-hand control panel.

All r-f circuits of the 20V-2 transmitter are straightforward and trouble free. A 6AU6 oscillator and 6SJ7 buffer are followed by an 807 which drives the parallel 4-400A tubes in the power amplifier. The oscillator, buffer and r-f driver plate circuits are contained within shielded plug-in units located behind the right front access door. For frequencies in the AM broadcast band, the oscillator employs a resistive load. As the 20V-2 transmitter is also available for high-frequency applications, provisions are included for replacing the resistor with a tuned tank circuit for frequency doubling. A frequency monitor connection is brought out from the grid circuit of the power amplifier. A resistor in the cathode circuit of the power amplifier acts as a low-impedance source for feeding an audio monitor speaker or amplifier.

The r-f output network consists of a pi section followed by an L-section and is designed to feed into impedances between 50 and 72* ohms. Harmonics are greatly attenuated in this network. There is a minimum of fundamental-frequency loss between the power amplifier and transmission line. Coil L-110 acts as a static drain and as a voltage source for feeding the modulation monitor. This coil is connected from the output end of the L-section to ground.

1.3. GENERAL DESCRIPTION OF AUDIO SECTION

The audio driver employs 6SJ7 pentodes in a push-pull amplifier circuit. The input to the audio system consists of a terminating pad that feeds the primary of the audio input transformer. An audio hum control is connected in the cathode circuit of the modulator. Type 4-400A tubes are used in the push-pull class AB₁ modulator. Approximately 12 db of feedback is provided from plates of the modulator tubes to grids of the first audio stage.

*Other impedances are available on special order.

1.4. GENERAL DESCRIPTION OF POWER SUPPLIES

There are separate power supplies for high voltage, low voltage, and bias. The high-voltage supply employs two type 575A half-wave mercury-vapor rectifiers in a full-wave circuit. It supplies d-c voltage for the plates of the modulators and the plates and screens of the power amplifier tubes. The low-voltage supply uses two type 866A half-wave mercury vapor rectifiers in a full-wave circuit to provide d-c voltage for plates and screens of the low power stages and screens of the modulator tubes. The bias supply employs a 5U4G high-vacuum rectifier in a full-wave circuit. It supplies bias to the r-f driver, modulator, and power amplifier tubes.

Overload protection is provided by magnetically-operated circuit breakers, by fuses in the primaries of the filament, low voltage, and bias transformers and by individual overload relays in the cathode circuits of the power amplifier and modulator. Instantaneous power change is accomplished by rotating the power-change switch inside the left-hand access door.

A thermal time delay is included in the control circuit to prevent application of plate voltage before the filaments reach operating temperature. A unique feature of this circuit is its ability to automatically select the proper time delay interval after short power interruptions. Instantaneous interruptions cause no delay in returning to the air.

Dual interlocks, both electrical and mechanical, are incorporated on each of the rear doors to provide double protection to personnel. Electrical interlocks of the split V-type open the primary circuits of the high and low voltage transformers whenever the rear doors are opened. The mechanical interlocks close, grounding the high-voltage circuits, after the electrical interlocks have opened the primary circuits.

Table 1-1. 20V-2 Transmitter Specifications

Power Output	250/500/1000 watts
R-F Output Impedance	50/72 ohms
Audio Input Impedance	600/150 ohms
Audio Input Level	+10 dbm \pm 2 db, pad input
Audio Response	\pm 2.0 db from 50 to 10,000 cps
Audio Distortion	Less than 3.0% from 50-7500 cps for 95% modulation including all harmonics up to 16 kc
Carrier Shift	Less than 3%
Residual Noise Level	60 db below 100% Modulation
Power Source	230/208 volts 50/60 cps single phase
Power Demand	Approximately 4.15 kw, 83% pf, at 100% modulation

Table 1-1. 20V-2 Transmitter Specifications (Cont.)

Temperature Range	+15°C (59°F) to 45°C (113°F)
Altitude Range	Sea level to 6000 feet
Weight	Approximately 1150 pounds
Dimensions	38" wide, 76" high, 27" deep

Table 1-2. Tube Complement

Item Number	Tube Type	Function
V-101	6AU6	Oscillator
V-102	✓ 6SJ7	Buffer Amplifier
V-103	✓ 807	R-F Driver
V-104	4-400A (8438)	Power Amplifier
V-105	4-400A	Power Amplifier
V-106	✓ 6SJ7	Audio Driver
V-107	✓ 6SJ7	Audio Driver
V-108	4-400A (8438)	Modulator
V-109	4-400A (8438)	Modulator
V-110	20V-2/5AV 5U4G	Bias Rectifier
V-111	(NL-SSR-14) S-575-A 575A	HV Rectifier
V-112	S-575-A 575A	HV Rectifier
V-113	(1N2637) 866A	LV Rectifier
V-114	(1N2637) 866A	LV Rectifier

SECTION 2 INSTALLATION

2.1. UNPACKING

To avoid damaging the equipment, use caution when uncrating the transmitter and components. All units should be inspected carefully. Check for loose screws and bolts. Inspect all controls, such as switches, for proper operation as far as can be determined without application of power. Examine cables and wiring, and make sure that all connections are tight and clear of each other and of the chassis. Claims for damage should be filed promptly with the transportation company.

2.2. LOCATION OF THE TRANSMITTER

It is recommended that the transmitter be placed in its permanent location before the units that were removed for shipping are replaced. The comparatively simple arrangements to accommodate power input, audio input, frequency monitoring, modulation monitoring, and audio monitoring are illustrated in figures 7-5 and 7-6. The external wiring requirements may be met by laying necessary conduit in a concrete floor, or by installing a wiring trench of sufficient size. Another alternative would be to build a false floor under which the necessary wires and cables can be placed. The trench will have to accommodate a three-wire power cable, two shielded twisted pairs, and two RG-8/U coaxial cables. It is very desirable to have several ties from the transmitter cabinet to the building's ground system.

Adequate clearance should be allowed in front of the transmitter. There should also be a clearance minimum of three and one-half to four feet behind the cabinet to provide sufficient room for service work.

2.3. REPLACEMENT OF UNITS REMOVED FOR SHIPPING

Several of the transmitter components have been removed and packed separately for safety in shipping. These include heavy units such as the high-voltage transformer, modulation transformer, high-voltage filter choke, large filter capacitors, and the small, fragile units such as tubes and crystals. The Inter-Unit Cabling Diagram, figure 7-6, and the Typical Installation Diagram, figure 7-5, as well as the photographic illustrations will be of assistance in replacing and connecting these components in the transmitter.

Wires and cables that were removed from the units to which they connect were tagged before shipment. Should any of these tags become lost, refer to the Inter-Unit Cabling Diagram, figure 7-6, for assistance in identifying the leads.

The following installation procedure is recommended:

a. Set the tubes and crystals aside. They should not be placed in the transmitter until all other units have been installed and connected. Reference to figure 6-3, 6-5, and 6-8 will aid in placing them in their proper positions.

CAUTION

EXTREME CARE SHOULD BE EXERCISED WHEN HANDLING THE CRYSTALS. THIS NEW TYPE OF CRYSTAL IS EXTREMELY FRAGILE. FOLLOWING ROUGH HANDLING THE CRYSTALS MAY STILL OSCILLATE, BUT MAY HAVE LOST THEIR HIGHLY IMPORTANT FREQUENCY VS. TEMPERATURE CHARACTERISTICS.

b. Note terminal numbers of the iron-core components before they are installed. Identification of these terminals is sometimes difficult after the components are in the transmitter.

c. Refer to figure 6-2 for the proper placement of the heavy iron-core components and install them in their proper locations in the lower part of the transmitter.

d. Check the station line voltage. Refer to figure 7-4 and make connections to the high-voltage transformer primary terminals that most nearly correspond to this voltage. If the nominal station voltage is very low, the 208-volt taps on the 575A filament transformer, the main filament transformer, and the low-voltage plate supply transformer should be used. The bias supply transformer primary is not tapped, but a correction may be made for a very low nominal line voltage by changing the value of the bias supply bleeder resistor, R-174, from 2000 to 2400 ohms.

CAUTION

DRESS ALL WIRES AWAY FROM THE HIGH VOLTAGE PLATE TRANSFORMER. FAILURE TO DO SO MAY RESULT IN VOLTAGE BREAKDOWN BETWEEN THE WIRE AND THE TRANSFORMER.

e. Refer to figures 6-2, 7-5, and 7-6 as well as the tags on the cables in order to make all possible connections at this time.

f. Install and secure the large filter capacitors in their proper positions as shown in figure 6-2 and make all connections to these units.

g. Remove the rear cover from the r-f output network and set the taps on tuning coil L-108 and loading coil L-109 to the positions shown in table 2-3 that correspond to the station operating frequency. The Collins Test Department data sheet included with the transmitter contains a record of the output network setup used for testing the transmitter at the factory. These conditions may not hold exactly under actual operating conditions, but are normally near enough to give a starting point for tuneup.

2.4 POWER INPUT CONNECTIONS

Refer to the Typical Installation Diagram, figure 7-5, for proper wire sizes and location of the power line accommodation hole in the bottom of the transmitter. Bring the neutral wire and the two power wires in through the rubber grommet in this hole and run them forward to the front panel. Connect the two power wires to the two outer terminals on terminal board E-100 illustrated in figure 6-1. The neutral wire should be connected to the center terminal of E-100.

2.5. AUDIO INPUT CONNECTIONS

The audio signal should be brought into the transmitter cabinet on a shielded twisted pair. Use the audio input hole illustrated in figure 7-5 for these wires. The audio input connections are made to terminal board E-103 located inside the lower shelf of the modulator chassis. The location of this terminal board can be seen in figure 6-6. Connect the two leads of the twisted pair to terminals 4 and 5 of E-103. Connect the shield to terminal 3 of E-103.

2.6. R-F OUTPUT CONNECTIONS

A solder type coaxial end seal terminal for connecting to the r-f output coaxial cable is located on top of the output network box and may be reached through a hole in the top of the cabinet. The coaxial cable leading to the antenna tuning house should be securely soldered to this terminal.

2.7. FREQUENCY MONITOR CONNECTIONS

Coaxial frequency monitor connector J-104 is located on the bottom of the r-f chassis. The transmitter is shipped with a mating plug connected to J-104. Bring a piece of RG-8/U coaxial cable through the proper hole in the floor of the cabinet, as shown in figure 7-5, and connect it to this plug.

2.8. MODULATION MONITOR CONNECTIONS

Coaxial modulation monitor connector J-100 is supplied with the proper mating plug. This connector is located on the top of the r-f output network box. Thread a piece of RG-8/U coaxial cable through the proper hole in the floor of the cabinet as shown in figure 7-5. Connect the coax to the plug associated with connector J-100.

2.9. AUDIO MONITOR CONNECTIONS

A shielded, twisted pair should be used for the audio monitor connections. Bring this wire through one of the monitoring lead holes in the bottom of the cabinet. The audio monitor terminal board, E-104, is located inside the lower part of the r-f chassis as shown in figure 6-9. Access to this terminal board can be gained by removing the lower cover of the r-f chassis. Connect one wire of the shielded twisted pair to one of the terminals on E-104. Connect the remaining wire and the grounded shield to the other terminal.

2.10. INTER-UNIT CABLING DIAGRAM

The Inter-Unit Cabling Diagram, figure 7-6, shows the parts of the transmitter in their general locations as viewed from the rear. Each section of this diagram is enclosed by broken lines. These sections have been given section designation letters that appear in the upper right-hand corner of each dotted enclosure. Although wiring between transmitter units is not shown on the diagram, the destination of this wiring is indicated by numbers and letters that appear directly below the arrow heads as shown in figure 2-1. The numbers to the right

of the lines above the arrow heads represent the type of wires used. The number directly to the right of each arrow head is the number of that point on the diagram and does not necessarily indicate that there is a terminal bearing that number at that point in the equipment. Where there are terminal boards with numbered terminals in the equipment, the terminals are represented on the diagram by small circles enclosing the number of the terminal. The terminal board is represented by a dotted line around all terminals on that board. Some sections of the diagram, such as section F, require that the terminal board in the diagram be broken to allow lines that do not terminate on that board to pass through the area on the diagram where the board is drawn.

A small portion of unit F from the Inter-Unit Cabling Diagram, figure 7-6, is shown in figure 2-1. The two KEO designations indicate that two KEO wires leave this point. The K in KEO indicates the type of wire (high voltage insulated cable). E indicates size of wire (#14 AWG). The O is a numeral indicating the color of the wire used (black). If a tracer were used on this wire an additional number would be added to indicate the color of the tracer. For example, if this wire were black with a red tracer, the designation would have been KEO2. If a shield were used, the wire would be called KESO2, the S indicating a shield. The color code used for wires and tracers is the same as that used for resistors and condensers.

The number 18 shown beside the arrow head indicates that this is point number 18 on the diagram.

A7 indicates that one of the wires leaving this point on the diagram goes to point 7 on unit A of the diagram. J7 indicates that one of the wires leaving this point on the diagram goes to point 7 on unit J of the diagram.

When coaxial cable, copper straps, and other types of connecting materials except wires are used, the "type of wire" code is not used. Instead of using a code, the connecting material is specified by name on the diagram, as in the case of the copper strap shown at point 1, unit C.

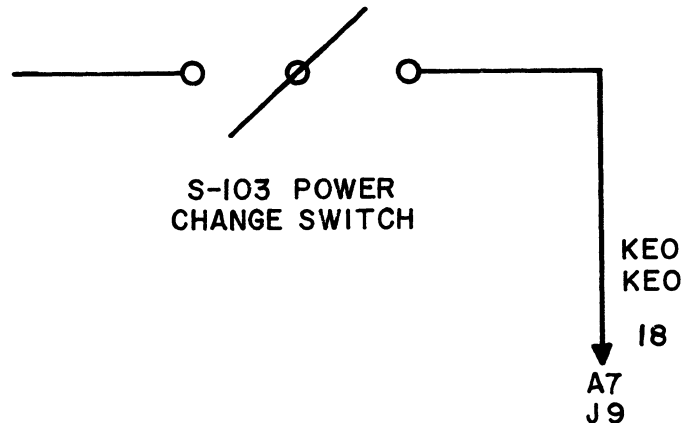

Figure 2-1. Inter-Unit
Cabling Example

Table 2-1. List of Wire Types

Letter	Type of Wire
A	AN-J-C-48
B	Busbar, Round Tinned Copper
C	JAN Type WL (600 volts)
D	Miniature JAN wire
F	Extra-Flexible Varnished Cambric
G	General Electric Deltabeston
K	Neon Sign Cable (15,000 volts)
N	Single Conductor Stranded (Not Rubber)
P	Single Conductor Stranded (Rubber Covered)
R	JAN Type SRIR (1000 volts)
V	JAN Type SRHV (2500 volts)

Table 2-2. List of Wire Sizes and Color Codes

Letter	Size of Wire (AWG)	Number	Color of Wire or Tracer
A	22	0	Black
B	20	1	Brown
C	18	2	Red
D	16	3	Orange
E	14	4	Yellow
F	12	5	Green
G	10	6	Blue
H	8	7	Violet
J	6	8	Grey
K	4	9	White
L	2		
M	1		
N	0		
P	00		
Q	000		
R	0000		

Cable Identification Example:

A JAN Type WL, #22 AWG, shielded, white wire with red tracer would be labeled CAS92. A black #14 AWG neon sign cable would be labeled KEO. A breakdown of these two descriptions is shown on the next page.

C	A	S	9	2
Type of Wire	Size of Wire		Color of Body	Color of Tracer
Jan Type WL	# 22 AWG	Shielded	White	Red
K	E	O		
Type of Wire	Size of Wire	Color of Body		
Neon Sign Cable	#14 AWG	Black		

2.11. CONTROL CIRCUIT CONNECTIONS

A 16-connection terminal board, E-105, is provided, at the rear of the power supply chassis, for control circuit connections. These terminals may be used to interlock the 20V-2 with other equipment. Remote control switches and indicator lights may also be connected to terminals on this board. A remote filament indicator lamp may be connected across terminals 4 and 5; 230 volts ac is present on these terminals at any time that the filament circuits in the transmitter are energized. In like manner, a 230-volt plate indicator lamp may be connected across terminals 10 and 11. For remote operation of the filament circuits, connect a normally open momentary switch between terminals 2 and 6 for filament starting, and remove the jumper between terminals 6 and 13 and connect a normally closed momentary switch to these terminals for filament stopping. A plate on switch with normally open momentary contacts may be connected to terminals 6 and 8, and a plate off switch with normally closed momentary contacts may be connected in place of the jumper between terminals 7 and 12. For simplified operation, the filament on and plate off switches may be eliminated; when the plate on switch is operated, both filament and plate power will be automatically applied in proper sequence. Operation of the filament off switch will shut down all filament and plate power that may be on.

2.12. ARC GAPS

Inspect the arc gaps listed below for burrs, scratches, or sharp edges. If any are found, remove them with crocus cloth. Set gaps as follows:

Plate tuning capacitor gap 5/16 to 21/64".

Loading capacitor gap 1/16 to 5/64".

Ant. coupling capacitor gap 1/32 to 3/64".

Modulation transformer gap 1/16 to 5/64".

Table 2-3. Approximate Output Tank Tuning Data

FREQ KC	C-190	C-151	C-150	C-149	C-148	C-145	C-142	L-108	L-107	FREQ KC
1600	← OUT →	938 2048 00 (430 MMF)	938 2048 00 (430 MMF)	938 2048 00 (430 MMF)	← OUT →	924 1022 00 (200 MMF)	913 1789 00 (750 MMF)	980 0040 00 (81uh) or as alternate 980 0041 00 (150uh)	← 571 0460 10 →	1600
1025										936 1149 00 (.022 MFD)
1020										1020
875										875
865					938 2062 00 (820 MMF)					865
725										725
715										715
675										675
665										665
575										575
565										565
550										550

SECTION 3 OPERATION

3.1. FILAMENT CONTROL

When the filament circuit breaker, S-106, is closed, depressing the filament on button will energize filament contactor K-103, applying 230 volts to its coil through filament on button S-111 and normally closed contacts of filament off button S-112. Holding contacts of K-103 shunt the contacts of S-111, maintaining the circuit after the button is released. Depressing the filament off button, S-112, opens its contacts, which are in series with S-111 and K-103, and de-energizes the relay.

3.2. TIME DELAY

When K-103 is initially energized, the circuit to the heater element of thermal time delay relay K-101 is completed through R-171, R-173, and the holding contacts of K-103. R-171 is provided as a means of adjusting the length of the time delay by adjusting the heater current. The closing of the contacts of K-101 lights filament lamp I-101 and prepares the plate circuit for operation. Also, R-172 is shunted across the heater element of K-101 and R-171, reducing the current through the element to a value just sufficient to hold the contacts closed.

K-101 contains a resistor heating element, a bimetal strip, and contacts. The temperature within the relay affects the bimetal element, causing the contacts to close when heated, and to open when cooled. The thermal inertia of the heating element and bimetal strip, being comparable to that of the tube filaments in the transmitter, causes this relay to automatically select the proper delay period to allow the tubes to come to their proper operating temperature. During short power interruptions, there will be little or no delay in returning to the air, as the tubes, and so, too, K-101, will not have cooled sufficiently to require the full delay interval. The length of the initial delay period from a cold start is adjustable from 10 seconds to 45 seconds by means of time delay adjustment R-171. A delay of 30 seconds is recommended. Turning the control clockwise will lengthen the delay. If the delay period is to be timed, make the check only when the transmitter has been shut down for several hours, as any residual heat from a previous run will shorten the delay interval. The filament lamp indicates the end of the time delay cycle.

3.3. PLATE CONTROL

If the filaments have been energized and the time delay cycle has been completed, depressing the plate on button, S-113, will close the circuit to plate hold relay K-104 through S-112, S-113, S-114, overload relays K-105 and K-106, and door interlocks S-108 and S-109; the contacts of K-104, in turn, energize plate contactor K-102 through contacts 3 and 4 of K-104, arc-suppression relay K-107, contacts 5 and 6 of K-104, and K-101. A pair of contacts of K-102, when closed, shunt the contacts of K-101, relieving them of continuous load.

It can be seen from the above that is the arc-suppression relay, K-107, is energized by a fault in the antenna circuit or final tank, the opening of its contacts will de-energize K-102 only. Since K-104 remains closed, the reclosing of K-107 will re-energize K-102 and return the transmitter to the air immediately. If one of the rear cabinet doors is opened, or if an overload occurs in the modulator or final, both K-104 and K-102 will be de-energized, and the plate on button must be depressed to return the transmitter to the air. Depressing the filament off button, S-112, will shut down the transmitter completely.

3.4. AUTOMATIC SEQUENCE STARTING

If desired, the transmitter may be started by pressing only the plate on button. The sequence of operation is as follows:

Depressing S-113 energizes K-104. K-104, through its contacts, energizes the filament contactor and time delay relay. At the end of the time delay interval, the closing of K-101 will automatically energize K-102, applying plate power to the transmitter.

3.5. CRYSTAL SELECTOR SWITCH

Crystal selector switch S-101 is located in the center of the area behind the lower right inspection plate as indicated in figure 6-11. The switch shaft is slotted for screwdriver operation. When the switch is turned to the right, the crystal toward the right side of the chassis (as viewed from the front of the transmitter) is selected.

3.6. CRYSTAL FREQUENCY TRIMMER CONTROLS

Crystal frequency trimmer controls C-101 and C-102 are located behind the lower right inspection plate as indicated in figure 6-11. These two controls provide for small adjustments in the crystal frequency. C-101, the upper control, adjusts the frequency of Y-101, the left-hand crystal as seen from the front of the transmitter.

3.7. MULTIMETER SWITCH

Multimeter switch S-102 is a two-pole seven-position switch located behind the left door on the front of the transmitter cabinet as shown in figure 6-11. This switch inserts multimeter M-104 into any one of seven transmitter circuits. Table 4-1 lists the multimeter switch positions and typical readings for these circuits. The full scale reading of the multimeter is indicated for each switch position.

3.8. FIRST R-F BUFFER TANK CIRCUIT TRIMMERS.

The first buffer tank circuit trimmers, C-114 and C-115, are screwdriver adjustments located behind the lower right inspection plate. The location of these two trimmers is shown in figure 6-11. They should be adjusted for maximum grid drive to the 807 r-f driver stage. The trimmers are connected in parallel as shown in figure 7-7. One of the trimmers should be adjusted to give a good

tuning range with the second trimmer, and all adjustments made with the second trimmer.

3.9. R-F DRIVER TANK TRIMMERS

C-125 and C-126, the r-f driver tank circuit trimmers, are screwdriver adjustments located behind the upper right inspection plate. The location of these two trimmers is shown in figure 6-11. They should be adjusted for maximum grid drive to the power amplifier. The trimmers are connected in parallel as shown in figure 7-7. One of the trimmers should be adjusted to give a good tuning range with the second trimmer, and all adjustments made with the second trimmer.

3.10. POWER AMPLIFIER PLATE TUNING AND LOADING CONTROLS

The power amplifier plate circuit tuning and loading controls, C-146 and C-147, are located behind the right-hand door on the front of the transmitter cabinet as shown in figure 6-11. The PA tuning control is used to resonate the power amplifier plate circuit. An increase in loading is obtained by reducing the capacity of the power amplifier loading capacitor, C-147, while simultaneously retuning the power amplifier plate circuit to resonance by means of the PA tuning control. With a pi-L output network of the type used in the 20V-2 transmitter, any adjustment of the PA loading control will detune the output network and cause the plate current to soar. Care must be exercised to keep the PA tuning at resonance whenever the PA loading control is adjusted. The loading should be increased until the r-f line current is slightly less than the desired value. The PA tuning control should then be adjusted slightly to the side of resonance that gives an increase in r-f line current. The power amplifier plate current will also increase; however, the increase in power to the r-f line constitutes a large proportion of the increase in power to the power amplifier circuit, thus yielding a higher plate efficiency. Adjust the PA tuning and PA loading controls to the point where the desired amount of r-f line current is obtained with the highest operating efficiency. The highest efficiency will always be obtained with the power amplifier plate circuit tuned slightly on the capacitive side of resonance.

3.11. POWER CHANGE SWITCH

Power change switch S-103 is located behind the left door on the front of the cabinet as shown in figure 6-11.

Two resistors in series with two parallel resistors are contained in the power amplifier plate circuit. POWER CHANGE switch S-103 shorts out these resistors for high power operation and removes the short for low power operation. A jumper strap is provided across the parallel resistors R-194 and R-195 for 500-watt operation on low power, and must be removed for 250-watt operation on low power. Tapped resistor R-196 is used to adjust low power output to exactly 250 or 500 watts. The POWER CHANGE switch may be operated whether the transmitter is broadcasting or not. Minor corrections in power output are made with the power amplifier tuning and loading controls.

3.12. PA DRIVE CONTROL

PA drive control R-182 is a screwdriver adjustment located behind the upper right-hand inspection plate as shown in figure 6-11. It is used to vary the r-f driver screen voltage in order to regulate the grid drive applied to the power

amplifier. PA drive control R-182 should be adjusted at the same time and in the same manner as audio hum control R-120, described in paragraph 3.13 below. When adjusted in this manner, optimum voltage will be applied to the r-f driver screen circuit.

3.13. AUDIO HUM CONTROLS

Audio hum control R-120 is a screwdriver adjustment located behind the upper right inspection plate as shown in figure 6-11. It is a variable resistor used to shift the ground point of the power amplifier filament circuit to a point which will minimize the hum caused by the a-c filament voltage. The other audio hum control, R-146, is the only control located behind the lower left inspection plate. The position of this screwdriver adjustment is indicated in figure 6-11. The operation of this control is the same as that of audio hum control R-210; it shifts the ground point of the modulator filament circuit to minimize hum.

In order to adjust audio hum controls R-120 and R-146, and PA drive control R-182, inject a 1000-cycle audio signal of sufficient amplitude to modulate the carrier 100 percent. Calibrate a noise meter, remove the modulation, and read the noise level. Adjust PA drive control R-182 for minimum noise. Adjust audio hum controls R-120 and R-146 to further reduce the noise level.

3.14. MODULATOR BIAS ADJUSTMENTS

Modulator bias adjustments R-162 and R-163 are located behind the upper left inspection plate as indicated in figure 6-11. These two screwdriver adjustments control the amount of negative bias applied to the grids of the individual modulator tubes. Turning R-162 counterclockwise increases the amount of bias applied to V-110, the modulator tube near the front of the cabinet. To adjust these two controls, inject a 1000-cycle signal for sufficient amplitude to modulate the carrier 95%. Vary R-162 and R-163 until minimum distortion is indicated on a distortion analyzer. R-149 can be used to adjust the total modulator plate current.

3.15. ARC-SUPPRESSION CIRCUIT

The arc-suppression circuit included in the 20V-2 will safeguard tubes and tank components by interrupting the plate voltages in the event of a short circuit or flashover in the transmitter r-f output circuit. The arc-suppression relay, K-107, has normally-closed contacts in series with the plate contactor coil. The coil of K-107 is connected in series with monitor coil L-110, as shown in figure 7-3. The end of the monitor coil that connects to the relay is bypassed to ground for rf. The bias supply is used to supply current for the operation of K-107. When an arc-over occurs in the power amplifier output network due to lightning or any other cause, the ionized path produced by the r-f voltage in the arc has a sufficiently low d-c resistance to complete the relay coil circuit and energize the relay. When the relay operates, its contacts open, disabling the high- and low-voltage plate supplies, removing the transmitter carrier from the air and stopping the arc-over. When the arc is extinguished, there is no path to ground for the d-c relay coil current, and its contacts close, returning the carrier to the air. Ordinarily, this complete operation will occur so quickly that only the click of the plate contactor will notify the operator that an arc-over has occurred.

3.16. STARTING THE EQUIPMENT IN A NEW INSTALLATION

- a. Before starting the transmitter for the first time, inspect it carefully for any mechanical damage.
- b. Be sure that all tubes are in their proper sockets, and that the crystals are in place.
- c. Inspect all door interlocks. Press on the contact block until the spring is completely compressed. Release the pressure. If the contact block does not spring out to its original position, check the interlock carefully and adjust it until it operates properly.
- d. Remove the plate caps from the two 866A and two 575A rectifiers. Make sure that the caps hang free and are not near any metal parts.
- e. Close both rear cabinet doors.
- f. Press the filament on button. The filament and time delay circuits should operate as described in paragraphs 3.1. and 3.2.
- g. Wait until the filament lamp lights, then press the plate on button; the plate lamp should light immediately.
- h. Press the filament off button; the transmitter should shut down completely.
- i. Remove the modulator tubes from the equipment.
- j. Replace the plate caps on the 866A low-voltage rectifiers only.
- k. Select the desired crystal, using crystal selector switch S-101. (See figure 6-11.)

CAUTION

OPERATION OF THIS EQUIPMENT INVOLVES THE USE OF HIGH VOLTAGES WHICH ARE DANGEROUS TO LIFE. OBSERVE SAFETY PRECAUTIONS. DO NOT MAKE ADJUSTMENTS INSIDE THE EQUIPMENT WITH HIGH VOLTAGE APPLIED. DO NOT DEPEND ON DOOR INTERLOCKS. ALWAYS SHUT DOWN THE EQUIPMENT WHEN MAKING ADJUSTMENTS.

- l. Apply power to the filaments and allow the transmitter to run for twenty minutes with only the filaments lighted. This operation is necessary in order to properly age the mercury vapor rectifier tubes. Aging is required for all new tubes and for used tubes that have been agitated or inverted.
- m. Press the plate on button.

n. Rotate the multimeter switch through the first four positions and check the readings with those given in table 4-1. Some deviation from these readings is to be expected.

o. Set the multimeter switch to the position designated 807 grid, 25 ma., and adjust the buffer plate tank trimmers for maximum 807 grid current. These two trimmers, C-114 and C-115, are located behind the lower right inspection plate, as shown in figure 6-11. The two trimmers are connected in parallel; one of the trimmers should be set to provide a good tuning range with the second.

p. Check the first buffer cathode current against table 4-1.

q. Set the multimeter switch to the position designated PA Grid, and tune the driver plate tank trimmers in the same manner as the buffer plate tank.

r. Shut down the power and replace the plate caps on the HV rectifiers. Replace the modulator tubes in their sockets.

s. Turn the two front-panel modulator bias adjustment controls, R-162 and R-163, to their maximum counterclockwise positions. Turn modulator bias adjustment R-149, located at the rear of the power supply chassis, to maximum clockwise position. This adjustment results in maximum bias and minimum modulator plate current.

t. Adjust the clip on the monitoring coil, L-110, located in the r-f tank compartment and illustrated in figure 6-7, to a position near the ground end of the coil.

u. Set the power change switch to the low position.

v. Set the PA loading control at 100. This adjustment produces minimum loading.

w. Close the rear cabinet doors and turn on filament and plate power.

x. As soon as the plate voltage is applied, adjust the PA tuning for minimum PA plate current.

y. Turn the multimeter switch to the PA grid position and retune the 807 r-f driver plate tank for maximum PA grid current.

z. Set modulator bias controls R-162 and R-163 to center of their rotation. Adjust modulator bias control R-149 on power supply chassis so that total modulator current is approximately 120 ma.

aa. Turn the power change switch to the high position and recheck the power amplifier plate tuning.

- bb. Recheck the driver plate tank for maximum PA grid current.
- cc. Increase the power amplifier loading to obtain the desired power output, using the method described in paragraph 3.10.
- dd. Adjust the tap on L-110 to obtain the desired output for the monitoring equipment.

3.17. ADJUSTMENT OF AUDIO SECTION

Apply a 1000-cycle tone of sufficient amplitude to modulate the r-f carrier 95 percent. Adjust the two modulator bias controls, R-162 and R-163, to obtain minimum distortion as measured with a distortion analyzer. R-149 may be readjusted as necessary to bring R-162 and R-163 into range. Total static current should remain near 120 ma.

Increase the level of the 1000-cycle modulating signal until 100% modulation is obtained. Calibrate a noise meter and remove the modulation. Read the noise level. Adjust PA drive control R-182 and audio hum controls R-120 and R-146 to reduce the noise to a minimum value. The location of these controls is shown in figure 6-11.

3.18. OVERLOAD RELAY ADJUSTMENT

To change the setting of the power amplifier overload relay, (see figure 6-10) remove the relay cover, turn the transmitter on and load it to operating values. Gradually change the setting of the thumb screw in the relay and momentarily run the power amplifier off tune and watch the PA plate current meter. Set the thumb screw at the desired drop-out point, retune to resonance and replace the relay cover. Reset the flag by pressing the plunger at the bottom of the relay.

To change the setting of the modulator overload relay, remove the relay cover, turn the transmitter on and load it to operating values. Set the thumb screw in the same manner as for power amplifier overload adjustment (above) except introduce an audio sine wave at 1000 cps into the audio input and run the gain up until proper overload drop out is established.

3.19. STARTING IN NORMAL OPERATION

- a. Close the rear cabinet doors.
- b. Depress the filament on button.
- c. Turn the power change switch to the correct position for the desired power output.
- d. Depress the plate on button.
- e. If the power output is to be adjusted, set the PA loading and PA tuning controls as described in paragraph 3.10.
- f. Record meter readings and monitoring observations. Typical meter readings are listed in table 4-1.

SECTION 4 MAINTENANCE

This transmitter has been constructed of materials considered to be the best obtainable for the purpose and has been carefully inspected and adjusted at the factory in order to reduce maintenance to a minimum. To insure peak performance and prevent failure or impairment of operation, adhere to a definite schedule of periodic checks and maintenance procedures.

4.1. ROUTINE MAINTENANCE

a. **CLEANING.** The greatest enemies to uninterrupted service in equipment of this type are dirt and corrosion. Corrosion is accelerated by the presence of moisture and dust. In certain localities it is impossible to keep moisture out of the equipment, but dust can be periodically removed by means of a soft brush or a dry, oil-free jet of air. There is always a slight accumulation of dust in the vicinity of high-voltage circuits. Remove dust as often as a perceptible quantity accumulates at any point in the equipment. It is very important to keep the moving parts such as tap switches free of dust in order to prevent undue wear. In general, it will be found that tap switch contacts, tube prongs, and cable connectors are most affected by corrosion. When the equipment is operated near salt water or in other corrosive atmospheres, switches, cables, plugs, and other parts should be inspected and cleaned more frequently in order to keep the equipment in operating condition.

The air filter should be cleaned approximately every two weeks. A small vacuum cleaner is a satisfactory device for removing surface dirt. Whenever the element becomes clogged, it should be removed, washed in carbon tetrachloride, and recharged by immersing in SAE 30 oil and allowing excess oil to drain off. If your transmitter is equipped with an aluminum air filter, follow cleaning instructions printed on the side of the filter. Replacement filters are part number 009 1069 00.

Check all connections at least once each month. Tighten any nuts, bolts, or screws that may have become loose. The contacts of cable connectors should be checked to insure clean, firm mechanical and electrical connections. Interlock switches should be inspected and cleaned weekly. Moving parts such as tuning controls should be checked regularly for excessive wear.

b. **LUBRICATION.** The bearings of the blower motor should be lubricated monthly with SAE 10 oil. Use only a small amount of lubricant at one time since too much oil will shorten the motor's life.

NOTE

Some models are supplied with blower motors having sealed bearings. These motors, identified by the absence of an oil cup, need no lubrication.

c. ROUTINE TUBE MAINTENANCE. Do not abuse tubes by operating them above their rated conditions. Keep a record of the length of time the tubes are in use. A check on the emission of all tubes should be made at least every 1000 hours of service. Replace tubes that have been in service for a long time. Spare, pre-aged mercury vapor rectifier tubes should be available for immediate replacement purposes. In order to have these tubes ready for emergency use they should be placed in the equipment during off-the-air hours and run for twenty minutes with only the filaments lighted. This will remove the mercury coating from the tube elements. The tubes should then be carefully removed from the equipment and stored in an upright position in a place where there is no possibility that they will be inverted or agitated. When preaged tubes are placed in the equipment they should be handled carefully in order to avoid the additional twenty-minute waiting period that will be required if mercury is allowed to come in contact with the tube elements.

4.2. TROUBLE SHOOTING

The most frequent cause of trouble in equipment of this type is tube failure. Check the tubes by replacing them with tubes that are known to be good and noting any change of performance. Low emission tubes may be the cause of erratic or poor performance of the equipment. If there is any doubt concerning the emission of a tube, it should be checked. Tube failure may cause distortion or hum. A tube suspected of causing this difficulty may be checked by replacing it with a tube that is known to be in good condition.

If the transmitter fails to start, circuits should be checked in the order in which they are made operative. The Primary Control Circuit Diagram, figure 7-1, should be of assistance in locating trouble in the primary circuits. Table 4-1, Typical Meter Readings, and table 4-2, Typical Voltages and Currents, are supplied as a reference of typical voltages and currents in an average 20V-2 transmitter. A list of typical readings of all panel meters of the individual transmitter should be made as an aid to rapid trouble shooting.

4.3. ORDERING REPLACEMENT PARTS

The guarantee, on the inside front cover, contains information on ordering replacement parts.

WARNING

OPERATION OF THIS EQUIPMENT INVOLVES THE USE OF VOLTAGES THAT ARE DANGEROUS TO LIFE. OPERATING PERSONNEL SHOULD AT ALL TIMES OBSERVE PROPER SAFETY PRECAUTIONS. DO NOT MAKE ADJUSTMENTS INSIDE THE CABINET WHILE ANY OF THE POWER SUPPLIES ARE OPERATING.

Table 4-1. Typical Meter Readings

Switch	Switch Position	Meter	Meter Reading
MULTIMETER SWITCH	AUDIO CATH. 25 MA.	MULTIMETER	9 ma.
MULTIMETER SWITCH	OSC. CATH. 25 MA.	MULTIMETER	5 ma.
MULTIMETER SWITCH	1ST BUFF. GRID 2.5 MA.	MULTIMETER	0.1 ma.
MULTIMETER SWITCH	1ST BUFF. CATH. 25 MA.	MULTIMETER	6.5 ma.
MULTIMETER SWITCH	807 GRID 25 MA.	MULTIMETER	1 ma.
MULTIMETER SWITCH	807 CATH. 250 MA.	MULTIMETER	55 ma.
MULTIMETER SWITCH	P.A. GRID 25 MA.	MULTIMETER	17 ma.
POWER CHANGE	LOW (250 W)	MOD PLATE CURRENT	
		Static	120 ma.
		75% mod.*	185 ma.
POWER CHANGE	LOW (250 W)	PA PLATE VOLTAGE	1560 volts
POWER CHANGE	LOW (250 W)	PA PLATE CURRENT	245 ma.
POWER CHANGE	LOW (250 W)	R.F. LINE CURRENT	
		70 ohm load	1.89 amp.
		50 ohm load	2.24 amp.
POWER CHANGE	LOW (550 W)	MOD. PLATE CURRENT	
		Static	120 ma.
		100% mod.*	320 ma.
POWER CHANGE	LOW (550 W)	P.A. PLATE VOLTAGE	2200 volts
POWER CHANGE	LOW (550 W)	P.A. PLATE CURRENT	330 ma.
POWER CHANGE	LOW (550 W)	R.F. LINE CURRENT	
		70 ohm load	2.8 amp.
		50 ohm load	3.3 amp.
POWER CHANGE	HIGH (1100 W)	MOD. PLATE CURRENT	
		Static	120 ma.
		100% mod.*	450 ma.

*With 1000 cycle sine wave

Table 4-1. Typical Meter Readings (Cont.)

Switch	Switch Position	Meter	Meter Reading
POWER CHANGE	HIGH (1100 W)	P.A. PLATE VOLTAGE	3100 volts
POWER CHANGE	HIGH (1100 W)	P.A. PLATE CURRENT	500 ma.
POWER CHANGE	HIGH (1100 W)	R.F. LINE CURRENT	
		70 ohm load	3.95 amp.
		50 ohm load	4.7 amp.

Table 4-2. Typical Voltages and Currents

Tube	Tube	Function	Normal Operating Characteristics	
V-101	6AU6	Crystal Oscillator	Plate Voltage	250 volts
			Crystal Current	1.6 ma.
			Cathode Current	4.0 ma.
V-102	6SJ7	Buffer Amplifier	Plate Voltage	290 volts
			Screen Voltage	135 volts
			Grid Current	0.1 ma.
			Cathode Current	6.5 ma.
V-103	807	R-F Driver Amplifier	Plate Voltage	550 volts
			Screen Voltages	260 volts
			Cathode Current	55 ma.
			Grid Current	1 ma.
V-104 V-105	4-400A	Power Amplifier	Output (watts)	1100 500 watts
			Plate Voltage	3100 2200 volts
			Plate Current	500 330 ma.
			Screen Voltage	470 330 volts
			Grid Current	20 20 ma.
			Plate Efficiency	73.5% 75.8%

Table 4-2. Typical Voltages and Currents (Cont.)

Tube	Type	Function	Normal Operating Characteristics	
V-106 V-107	6SJ7	Audio Amplifier	Plate Voltage	265 volts
			Cathode Current	9 ma. total
V-108 V-109	4-400A	Modulator	Plate Voltage	3100 volts
			Cathode Current	
			No Signal	120 ma.
			100% mod (1100W)	450 ma.
			100% mod (550W)	320 ma.
V-110	5U4G	Bias Voltage Rectifier	Voltage	-110 volts
		(Values are output from filter)	Current	100 ma.
V-111 V-112	575A	High Voltage Rectifier	Voltage	3100 volts
		(Values are output from filter)	Current	1 amp.
V-113 V-114	866A	Low Voltage Rectifier	Voltage	500 volts
		(Values are output from filter)		250 ma.

Table 4-3. Primary Power Input

	Kva	Kw	p.f.
Filaments and blowers only	0.78	0.66	85%
550 watts output, no modulation	3.28	2.45	75%
550 watts output, 100% modulation	4.0	3.2	80%
1100 watts output, no modulation	3.7	2.95	80%
1100 watts output, 100% modulation	4.82	4.0	83%

SECTION 5 PARTS LIST

20V-2 Parts List

Item	CIRCUIT FUNCTION	DESCRIPTION	PART NUMBER
B-101	Modulator blower	BLOWER: modified, consists of blower (009 1028 00) or alternate blower (009 1029 00)	542 3175 003
B-102	R-F chassis blower	Same as B-101	
B-103	Cabinet intake fan	BLADE: fan MOTOR: fan, 230 v 60 cy 1 phase	009 1226 00 230 0164 00
C-101	Crystal frequency trimmer for Y-101	CAPACITOR: variable, 7.5 uuf to 102.7 uuf	922 0028 00
C-102	Crystal frequency trimmer for Y-102	Same as C-101	
C-103	Crystal oscillator feedback coupling	CAPACITOR: mica, 1000 uuf p/m 20%, 3500 wvdc	914 0019 00
C-104	Crystal oscillator cathode bypass	CAPACITOR: mica, 0.01 uf p/m 5% 500 wvdc	910 1103 10
C-105	Crystal oscillator screen bypass	CAPACITOR: mica, 150 uuf p/m 20%, 500 wvdc	935 0114 00
C-106	Crystal oscillator plate coupling	CAPACITOR: mica, 5100 uuf p/m 5%, 500 wvdc	935 2105 00
C-107		Not used	
C-108		Not used	
C-109	Multimeter bypass	Same as C-104	
C-110	Crystal oscillator plate decoupling	Same as C-104	
C-111	Buffer cathode bypass	Same as C-104	
C-112	Buffer screen bypass	Same as C-104	
C-113	Buffer plate tank padder	CAPACITOR: mica, 100 uuf p/m 10%, 500 wvdc	912 0495 00

20V-2 Parts List

ITEM	CIRCUIT FUNCTION	DESCRIPTION	PART NUMBER
C-114	Buffer plate tank trimmer, p/o T-102	CAPACITOR: variable, double, 5-10 uuf min, 100-105 uuf max	922 4800 00
C-115	Buffer plate tank trimmer, p/o T-102	Same as C-114	
C-116	Driver grid-cathode compensator	CAPACITOR: ceramic, 20 uuf p/m 5%, 500 wvdc	916 4188 00
C-117		Not used	
C-118		Not used	
C-119	Buffer plate coupling	Same as C-106	
C-120	Buffer plate de-coupling	Same as C-104	
C-121	Multimeter bypass	Same as C-104	
C-122	Driver cathode bypass	Same as C-104	
C-123	Driver screen bypass	Same as C-104	
C-124	Driver plate tank padder	Same as C-113	
C-125	Driver plate tank trimmer, p/o T-103	Same as C-114	
C-126	Driver plate tank trimmer, p/o T-103	Same as C-114	
C-127		Not used	
C-128		Not used	
C-129	Driver plate de-coupling	Same as C-103	
C-130	Low level stages decoupling	CAPACITOR: mica, 0.01 uf p/m 20%, 1200 wvdc	936 1127 00

20V-2 Parts List

ITEM	CIRCUIT FUNCTION	DESCRIPTION	PART NUMBER
C-131	Neutralizing	CAPACITOR: vacuum, 15 uuf p/m 10%, 17,000 wvdc	919 0063 00
C-132	Driver plate coupling	Same as C-103	
C-133	Multimeter bypass	Same as C-104	
C-134	PA filament bypass	Same as C-104	
C-135	PA filament bypass	Same as C-104	
C-136	PA filament bypass	Same as C-104	
C-136	PA filament bypass	Same as C-104	
C-137	PA filament bypass	Same as C-104	
C-138	PA screen bypass	CAPACITOR: ceramic, 67 uuf p/m 5%, 5000 wvdc	913 0090 00
C-139	PA screen bypass	Same as C-138	
C-140	PA plate current meter bypass	Same as C-106	
C-141	PA plate decoupling	CAPACITOR: ceramic, 500 uuf plus 50% minus 20%, 20,000 wvdc	913 1101 00
C-142	PA plate tank coupling	CAPACITOR: ceramic, 750 uuf p/m 30%, 7500 wvdc	913 1789 00
C-142A	PA plate tank coupling	CAPACITOR: same as C142	913 1789 00
C-143	PA screen bypass	Same as C-138	
C-144	PA screen bypass	Same as C-138	
C-145	PA plate tank padder	CAPACITOR: air, fixed, 200 uuf	924 1022 00
C-145A	Additional PA plate tank padder (550-890 kc)	CAPACITOR: ceramic, 200 uuf p/m 10%, 7500 wvdc	913 1441 00
C-145B	Additional PA plate tank padder (550-700 kc)	Same as C-145A	

20V-2 Parts List

ITEM	CIRCUIT FUNCTION	DESCRIPTION	PART NUMBER
C-146	PA plate tuning	CAPACITOR: air, variable, 60 uuf min, 188 uuf max	920 0075 00
C-147	Loading	CAPACITOR: air, variable, 840 uuf max	920 0114 00
C-148	Output network padder (550-700 kc)	CAPACITOR: mica, 2000 uuf, p/m 5%, 5000 tv wvdc	938 2080 00
C-148A	Output network padder (710-890 kc)	CAPACITOR: mica, 820 uuf p/m 5%, 5000 wvdc	938 2062 00
C-149	Output network padder (600-1600 kc)	CAPACITOR: mica, 430 uuf p/m 5%, 5000 wvdc	938 2048 00
C-149A	Output network padder (550-600 kc)	Same as C-148A	
C-150	Output network padder (550-1040 kc)	Same as C-148A	
C-150A	Output network padder (1050-1600 kc)	Same as C-149	
C-151	Output network padder (550-1040 kc)	Same as C-148A	
C-151A	Output network padder (1050-1600 kc)	Same as C-149	
C-152	PA plate decoupling	Same as C-141	
C-153	Multimeter bypass	Same as C-106	
C-154	Audio feedback divider	CAPACITOR: mica, 3300 uuf p/m 20%, 1200 wvdc	936 0283 00
C-155	Audio feedback divider	Same as C-154	
C-156	Audio driver screen bypass	CAPACITOR: paper, 0.1 uf p/m 10%, 600 wvdc	961 5114 00
C-157		Not used	
C-158	Audio driver plate coupling	Same as C-156	
C-159	Audio driver plate coupling	Same as C-156	

20V-2 Parts List

ITEM	CIRCUIT FUNCTION	DESCRIPTION	PART NUMBER
C-160	Modulator filament bypass	Same as C-104	
C-161	Modulator filament bypass	Same as C-104	
C-162	Audio driver plate decoupling	CAPACITOR: paper, 2 uf p/m 10%, 600 wvdc	930 0046 00
C-163	Modulation transformer blocking	CAPACITOR: paper, 2 uf p/m 20%, 4000 wvdc	930 0041 00
C-164	PA plate voltage meter bypass	Same as C-106	
C-165	Driver filament bypass	Same as C-104	
C-166	Driver filament bypass	Same as C-104	
C-167	Bias supply filter	CAPACITOR: paper, 8 uf p/m 10%, 600 wvdc	930 0048 00
C-168		Not used	
C-169	HV filter resonator	CAPACITOR: paper, 0.08 uf p/m 10%, 7500 wvdc	930 0467 00
C-169A	HV filter	CAPACITOR: paper 0.11 uf $\pm 5\%$, wvrms 2400	930 0525 00
C-170	HV filter	CAPACITOR: paper, 4 uf p/m 20%, 4000 wvdc	930 0045 00
C-171	Modulator plate current meter bypass	Same as C-106	
C-172	LV filter	CAPACITOR: paper, 10 uf p/m 10%, 1000 wvdc	930 0038 00
C-173	LV filter	Same as C-172	
C-174	Audio feedback divider	CAPACITOR: mica, 47 uuf p/m 20%, 2500 wvdc	936 0162 00
C-175	Audio feedback divider	Same as C-174	
C-176	Audio feedback divider	Same as C-174	
C-177	Audio feedback divider	Same as C-174	

20V-2 Parts List

ITEM	CIRCUIT FUNCTION	DESCRIPTION	PART NUMBER
C-178	Audio feedback divider	Same as C-174	
C-179	Audio feedback divider	Same as C-174	
C-180	Audio feedback divider	Same as C-174	
C-181	Audio feedback divider	Same as C-174	
C-182	Modulator screen bypass	Same as C-130	
C-183	Modulator grid bypass	CAPACITOR: paper, 0.25 uf p/m 10%, 600 wvdc	961 5132 00
C-184	HV filter	Same as C-170	
C-185	Frequency monitor output coupling	Same as C-104	
C-186		Not used	
C-187	Modulator grid bypass	Same as C-183	
C-188	Modulation monitor coil bypass	CAPACITOR: mica, 22,000 uuf p/m 20%, 600 wvdc	936 1149 00
C-189	Modulation monitor output coupling	Same as C-104	
C-190	Additional modulation monitor coil bypass (550-800 kc)	Same as C-188	
C-191		Not used	
C-192	R-F output coupling	CAPACITOR: mica, 0.01 uf p/m 10%, 2500 wvdc	937 2025 00
C-193	Additional r-f output coupling	Same as C-192	
C-194		Not used	
C-195	Modulator overload bypass	CAPACITOR: dry electrolytic, 1100 uf	184 2000 00

20V-2 Parts List

ITEM	CIRCUIT FUNCTION	DESCRIPTION	PART NUMBER
C-196	R-F overload bypass	Same as C-195	
C-197	Audio bypass K-107	Same as C-162	
E-100	Primary power input	TERMINAL BOARD: 3 terminals	306 0069 00
E-101	Audio chassis	TERMINAL BOARD: 13 terminals	367 5130 10
E-102	R-F chassis	Same as E-101	
E-103	Audio input	TERMINAL BOARD: 5 terminals	367 4050 00
E-104	Audio monitor output	TERMINAL BOARD: 2 terminals	367 4020 00
E-105	Remote control	TERMINAL BOARD: 16 terminals	367 5160 00
F-101	Bias supply	FUSE: cartridge, 3AG, 1 amp, 250 v, Slo-Blo	264 4280 00
F-102	HV rectifier filament	Same as F-101	
F-103	Filament	FUSE: cartridge, 3AG, 3 amp, 250 v, Slo-Blo	264 0009 00
F-104	LV supply	Same as F-101	
I-101	Filament at operating temperature	BULB: candelabra base, 230-250 v, 10 w	262 0169 00
I-102	Meter panel lamp	BULB: Lumiline, disc base, 110 v, 40 w	262 0170 00
I-103	Meter panel lamp	Same as I-102	
I-104	Plate on lamp	Same as I-101	
J-100	Modulation monitor output	CONNECTOR: coaxial female, chassis mtg, for RG-8/U cable connector	357 9005 00
J-101	Audio chassis	CONNECTOR: female, chassis mtg, 4 contacts	364 2040 00
J-102	Audio chassis	CONNECTOR: female, chassis mtg, 8 contacts	366 2080 00
J-103	R-F chassis	Same as J-102	
J-104	Frequency monitor output	Same as J-100	

20V-2 Parts List

ITEM	CIRCUIT FUNCTION	DESCRIPTION	PART NUMBER
J-105	Modulator blower	CONNECTOR: female, chassis mtg, 4 prong	366 2040 00
J-106	R-F chassis blower	Same as J-105	
K-101	Time delay	RELAY: time delay, thermal, 117 v a-c heater, operating time 20 p/m 3 sec, NO contacts 3a 250 v ac	402 0211 00
K-102	Plate contactor	RELAY: power contactor, 220 v ac coil, 3 NO contacts 25a 600 v ac	401 1201 00
K-103	Filament contactor	RELAY: power contactor, 220 v ac coil, 3 NO contacts 10a 600 v ac	401 1202 00
K-104	Plate hold	RELAY: armature, 1430 ohm p/m 10% coil, 2 NO contacts left 2a right 1a 230 v ac	405 0608 00
K-105	Modulator overload	RELAY: current overload; ac or dc, 0.2 to 0.8 amp, 2 NC contacts	405 0186 00
K-106	R-F overload	Same as K-105	
K-107	Arc suppression	RELAY: armature, 5000 ohm coil, NC contacts 2.0a 230 v ac	970 1727 00
L-101*	Oscillator plate tank	COIL: part of T-101	
L-102	Buffer plate tank	COIL: part of T-102	
L-102A	Part of L-102		
L-102B	Part of L-102		
L-103*			
L-104	Driver plate tank	COIL: part of T-103	
L-104A	Part of L-104		
L-104B	Part of L-104		
L-105*			
L-106	Driver plate choke	R-F CHOKE: 1 mh p/m 10%, 300 ma, 10 ohms dc, 1.5 uuf max. dist cap	240 5800 00

*Not used at broadcast frequencies

20V-2 Parts List

ITEM	CIRCUIT FUNCTION	DESCRIPTION	PART NUMBER
L-107	PA plate choke	R-F CHOKE: 200 turns #24 AWG DS wire	571 0460 10
L-108	PA plate tank (710-1600 kc)	INDUCTOR: rf, 81 uh, 42 turns copper strip silver plated	980 0040 00
L-108	PA plate tank (550-700 kc)	INDUCTOR: rf, 150 uh, 56 turns copper strip silver plated	980 0041 00
L-109	Output network	INDUCTOR: rf, 30 turns #10 AWG wire	504 9624 003
L-110	Static drain/ modulation monitor	INDUCTOR: rf, 56 turns #22 AWG wire	506 9995 003
L-111	Modulation choke	REACTOR: modulation, 50 hy, 0.5 amp dc, 190 ohms max, 8500 tv rms, 50-10,000 cps p/m 1 db	678 0591 00
L-112	Bias filter	REACTOR: 12 hy, 80 ma, 375 ohms dc, 2000 tv rms	668 0004 00
L-113	HV filter	REACTOR: 10 hy min, 1.0 amp, 50 ohms max, 9000 tv rms	678 0625 00
L-114	HV filter	Same as L-113	
L-115	LV filter	REACTOR: 6.5 hy min, 0.2 amp, 85 ohms max, 2500 tv rms	678 0384 00
L-116	LV filter	Same as L-115	
M-101	R-F line current	METER: r-f ammeter, range 0-6 amp	451 0082 00
M-102	PA plate current	METER: d-c milliammeter, range 0-800 ma, 0.2 ohm p/m 2%	450 0095 00
M-103	PA plate voltage	METER: d-c voltmeter, 0-4000 v scale, 0-1 ma movement, 46 ohm p/m 20%	458 0196 00
M-104	Multimeter	METER: d-c milliammeter, 0-25 ma scale, 0-1 ma movement, 46 ohms p/m 20%	458 0170 00
M-105	Mod. plate current	Same as M-102	
P-100	Mates with J-100	CONNECTOR: coaxial plug for RG-8/U cable	357 9014 00

20V-2 Parts List

ITEM	CIRCUIT FUNCTION	DESCRIPTION	PART NUMBER
P-101	Mates with J-101	CONNECTOR: plug, 4 prong	363 8042 00
P-102	Mates with J-102	CONNECTOR: plug, 8 prong	365 8080 00
P-103	Mates with J-103	Same as P-102	
P-104	Mates with J-104	Same as P-100	
P-105	Mates with J-105	CONNECTOR: plug, 4 prong	365 8040 00
P-106	Mates with J-106	Same as P-105	
R-101	Crystal oscillator grid	RESISTOR: 0.1 megohm p/m 10%, 1/2 w	745 1170 00
R-102	Crystal oscillator cathode	RESISTOR: 220 ohm p/m 10%, 1/2 w	745 1058 00
R-103	Crystal oscillator plate load	RESISTOR: 10,000 ohm p/m 10%, 1 w, part of T-101	745 3128 00
R-104	Crystal oscillator screen	RESISTOR: 82,000 ohm p/m 10%, 1/2 w	745 1167 00
R-105	Crystal oscillator voltage dropping	RESISTOR: 0.12 megohm p/m 10%, 2 w	745 9185 00
R-106	Crystal oscillator voltage dropping	Same as R-105	
R-107	Buffer grid	Same as R-101	
R-108	Multimeter shunt	RESISTOR: 3900 ohm p/m 10%, 1/2 w	745 1111 00
R-109	Frequency monitor voltage divider	RESISTOR: 56 ohm p/m 10%, 2 w	745 9045 00
R-110	Buffer cathode	Same as R-102	
R-111	Buffer screen voltage divider	RESISTOR: 39,000 ohm p/m 10%, 1 w	745 3419 00
R-112	Buffer screen	RESISTOR: 33,000 ohm p/m 10%, 2 w	745 5715 00
R-113	Buffer voltage dropping	RESISTOR: 25,000 ohm p/m 10%, 10 w	710 1254 20
R-114	Driver grid	RESISTOR: 15,000 ohm p/m 10%, 1 w	745 3401 00

20V-2 Parts List

ITEM	CIRCUIT FUNCTION	DESCRIPTION	PART NUMBER
R-115	Driver cathode	RESISTOR: 22 ohm p/m 10%, 2 w	745 9027 00
R-116	Driver stabilizing	RESISTOR: 47 ohm p/m 10%, 1/2 w	745 1030 00
R-117	Driver screen voltage divider	RESISTOR: 22,000 ohm p/m 10%, 2 w	745 9153 00
R-118		Not used	
R-119	PA grid	RESISTOR: 15,000 ohm p/m 20%, 25 w	710 3154 00
R-120	Audio hum control	RESISTOR: variable, 50 ohm p/m 10%, 25 w	735 0201 00
R-121	Audio monitor voltage dropping	RESISTOR: 12.6 ohm p/m 20%, 20 w	710 0044 00
R-122	PA screen	RESISTOR: 2000 ohm p/m 5%, 25 w	710 3241 00
R-123	Bias voltage divider	Same as R-114	
R-124	Driver grid	RESISTOR: 4700 ohm p/m 10%, 1 w	745 3380 00
R-125	Multimeter shunt	RESISTOR: 220 ohms \pm 10%, 1/2 w	745 1324 00
R-126	Multimeter shunt	Same as R-125	745 1324 00
R-127	Multimeter series	RESISTOR: 5100 ohm p/m 5%, 1/2 w	745 1116 00
R-128	Audio input pad	RESISTOR: 100 ohm p/m 10%, 1/2 w	745 1310 00
R-129	Audio input pad	Same as R-128	
R-130	Audio input pad	Same as R-128	
R-131	Audio input pad	Same as R-128	
R-132	Audio input pad	RESISTOR: 820 ohm p/m 10%, 1/2 w	745 1349 00
R-133	Audio driver grid	RESISTOR: 68,000 ohm p/m 10%, 1/2 w	745 1163 00
R-134	Audio driver grid	Same as R-133	
R-135	Audio feedback voltage divider	RESISTOR: 18,000 ohm p/m 5%, 2 w	745 9149 00
R-136	Audio feedback voltage divider	Same as R-135	
R-137	Audio driver cathode	RESISTOR: 2200 ohm p/m 10%, 1/2 w	745 1100 00

20V-2 Parts List

ITEM	CIRCUIT FUNCTION	DESCRIPTION	PART NUMBER
R-138	Multimeter shunt	Same as R-102	
R-139	Audio driver voltage dropping	RESISTOR: 8200 ohm p/m 10%, 2 w	745 9136 00
R-140	Surge suppressor	RESISTOR: 22,000 ohms \pm 10%, 1 w	745 3142 00
R-141	Surge suppressor	Same as R-140	745 3142 00
R-142	Audio driver screen	RESISTOR: 160,000 ohm p/m 5%, 2 w	745 5745 00
R-143	Audio driver screen voltage divider	RESISTOR: 82,000 ohm p/m 10%, 2 w	745 9178 00
R-144	Audio driver plate load	Same as R-143	
R-145	Audio driver plate load	Same as R-143	
R-146	Audio hum control	Same as R-120	
R-147		Not used	
R-148		Not used	
R-149	Bias adjustment	RESISTOR: variable, 4000 ohm p/m 10%, 4 w	377 0040 00
R-150	Bias divider	RESISTOR: 1000 ohm p/m 10%, 2 w	745 5652 00
R-151	Audio feedback voltage divider	RESISTOR: 1.0 megohm p/m 10%, 2 w	745 9223 00
R-152	Audio feedback voltage divider	Same as R-151	
R-153	Audio feedback voltage divider	Same as R-151	
R-154	Audio feedback voltage divider	Same as R-151	
R-155	Audio feedback voltage divider	Same as R-151	
R-156	Audio feedback voltage divider	Same as R-151	

20V-2 Parts List

ITEM	CIRCUIT FUNCTION	DESCRIPTION	PART NUMBER
R-157	Audio feedback voltage divider	Same as R-151	
R-158	Audio feedback voltage divider	Same as R-151	
R-159	Modulator grid	RESISTOR: 47,000 ohm p/m 10%, 2 w	745 9167 00
R-160	Modulator grid	RESISTOR: 82,000 ohm p/m 10%, 1 w	745 3167 00
R-161	Modulator grid	Same as R-160	
R-162	Bias adjustment	RESISTOR: variable, 25,000 ohm p/m 10%, 4 w	377 0011 00
R-163	Bias adjustment	Same as R-162	
R-164	Modulator stabilizer	RESISTOR: 10,000 ohm p/m 10%, 1/2 w	745 1128 00
R-165	Modulator stabilizer	Same as R-164	
R-166	Power reducing	RESISTOR: 5000 ohm p/m 10%, 160 w	710 6542 00
R-167	Power reducing	Same as R-166	
R-168	PA plate voltmeter shunt	RESISTOR: 10,000 ohm p/m 10%, 2 w	745 9139 00
R-169	PA plate voltmeter multiplier	RESISTOR: 4.0 megohm, special	505 5098 002
R-170	Audio screen	Same as R142	
R-171	Time delay adjust	RESISTOR: variable, 2000 ohm p/m 10%, 4 w	377 0008 00
R-172	Time delay shunt	RESISTOR: 15,000 ohm p/m 10%, 10 w	710 1154 20
R-173	Time delay voltage dropping	RESISTOR: 2500 ohm p/m 10%, 10 w	710 0030 00
R-174*	Bias bleeder	RESISTOR: 2000 ohm p/m 10%, 25 w	710 3242 00
R-175	HV bleeder	RESISTOR: 20,000 ohm p/m 5%, 100 w	710 2134 00
R-176	HV bleeder	Same as R-175	
R-177	HV bleeder	RESISTOR: 40,000 ohm p/m 10%, 100 w	710 5404 20

*See paragraph 2.3.d.

20V-2 Parts List

ITEM	CIRCUIT FUNCTION	DESCRIPTION	PART NUMBER
R-178	LV bleeder	RESISTOR: 7500 ohm p/m 10%, 100 w	710 0132 00
R-179		Not used	
R-180	Driver screen	RESISTOR: 25,000 ohm p/m 10%, 10 w	710 1254 20
R-181		Not used	
R-182	PA drive control	Same as R-162	
R-183**	HV primary voltage dropping	RESISTOR: 15 ohm p/m 10%, 25 w	710 3152 00
R-184	Meter lamp series	RESISTOR: 100 ohm p/m 10%, 25 w	710 3100 20
R-185		Not used	
R-186	Modulator grid	RESISTOR: 0.15 megohm p/m 10%, 2 w	745 9188 00
R-187	Modulator grid	Same as R-186	
R-188	K-105 shunt	RESISTOR: 25 ohm p/m 10%, 25 w	710 3252 00
R-189	K-105 transient filter	RESISTOR: 25 ohm p/m 10%, 10 w	710 1252 00
R-190	K-105 transient filter	Same as R-189	
R-191	K-106 shunt	Same as R-188	
R-192	K-106 transient filter	Same as R-189	
R-193	K-106 transient filter	Same as R-189	
S-101	Crystal selector	SWITCH: rotary, 2 pole, 2 position	259 0362 00
S-102	Multimeter switch	SWITCH: rotary, 2 pole, 8 position	259 0441 00
S-103	Power change	SWITCH: rotary, high voltage, SPST, special	504 9633 003
S-104	HV shorting interlock	SHORTING BAR: gravity operated	
S-105	HV shorting interlock	SHORTING BAR: gravity operated	
S-106	Filament breaker	CIRCUIT BREAKER: magnetic, 5 amp, 230 v ac	260 0239 00
S-107	Plate breaker	CIRCUIT BREAKER: magnetic, 20 amp, 230 v ac	260 0225 00

**Shorted by a jumper and not used in 20V-2 transmitters

20V-2 Parts List

ITEM	CIRCUIT FUNCTION	DESCRIPTION	PART NUMBER
S-108	Door interlock	CONTACT ASSEMBLY: male CONTACT ASSEMBLY: female	260 4040 00 260 4050 00
S-109	Door interlock	Same as S-108	
S-110		Not used	
S-111	Filament on	SWITCH: push, black button, 40 amp 110 v, 20 amp 220 v, 13 amp 440 v ac	260 0355 00
S-112	Filament off	SWITCH: push, red button, 40 amp 110 v, 20 amp 220 v, 13 amp 440 v ac	260 0352 00
S-113	Plate on	Same as S-111	
S-114	Plate off	Same as S-112	
T-101	Oscillator plate tank (550-1600 kc)	OSCILLATOR PLATE TANK ASSEMBLY: includes R-103	504 9594 002
T-101	Oscillator plate tank (high freq.)	OSCILLATOR PLATE TANK ASSEMBLY	
T-102	Buffer plate tank	INTERMEDIATE PLATE TANK ASSEMBLY: includes C-113, C-114, C-115, L-102A, L-102B	504 9632 003
T-103	Driver plate tank	Same as T-102; includes C-124, C-125, C-126, L-104A, L-104B	
T-104	Audio input	TRANSFORMER: input audio, pri 600 ohm CT, sec 50,000 ohm CT	677 0114 00
T-105	Modulation	TRANSFORMER: modulation	667 0497 00
T-106	Bias supply	TRANSFORMER: power, pri 230 v 2500 tv rms, Secondaries: #1 360/320/280/240 v CT 150 ma 2500 tv rms #2 5.0 v 3.0 amp 2500 tv rms	672 0392 00
T-107	HV rectifier filament	TRANSFORMER: filament, pri 230/208 v 50/60 cps 2500 tv rms, sec 5.0 v CT 20 amp 10,000 tv rms	662 0209 00
T-108	HV plate	TRANSFORMER: power, pri 230/208 v 50/60 cps with taps for 3200 v dc output at power supply terminals	672 0385 00

20V-2 Parts List

ITEM	CIRCUIT FUNCTION	DESCRIPTION	PART NUMBER
T-109	Filament	TRANSFORMER: filament, pri 230/208 v 50/60 cps 2500 tv rms, Secondaries: #1 5.3 v CT 30 amp 2500 tv rms #2 5.3 v CT 30 amp 2500 tv rms #3 6.3 v 3.0 amp 2500 tv rms #4 2.5 v 10 amp 2500 tv rms	672 0381 00
T-110	LV plate	TRANSFORMER: power, pri 230/208 v 50/60 cps; sec 550 v 280 ma dc at power supply terminals	672 0383 00
V-101	Crystal oscillator	TUBE: pentode, 6AU6	255 0202 00
V-102	Buffer	TUBE: pentode, 6SJ7	255 0030 00
V-103	R-F driver	TUBE: beam tetrode 807	256 0033 00
V-104	Power amplifier	TUBE: tetrode 4-400A	256 0091 00
V-105	Power amplifier	Same as V-104	
V-106	Audio driver	Same as V-102	
V-107	Audio driver	Same as V-102	
V-108	Modulator	Same as V-104	
V-109	Modulator	Same as V-104	
V-110	Bias rectifier	TUBE: rectifier 5U4G	255 0032 00
V-111	HV rectifier	TUBE: rectifier 575A	256 0080 00
V-112	HV rectifier	Same as V-111	
V-113	LV rectifier	TUBE: rectifier 866A	256 0049 00
V-114	LV rectifier	Same as V-113	
Y-101	Crystal	CRYSTAL: quartz, low temperature coefficient	
Y-102	Crystal	Same as Y-101	
XF-101	Holder for F-101	HOLDER: fuse, for single 3AG type	265 1040 00
XF-102	Holder for F-102	Same as XF-101	
XF-103	Holder for F-103	Same as XF-101	
XF-104	Holder for F-104	Same as XF-101	
XI-101	Socket for I-101	SOCKET: lamp, candelabra screw base	262 0255 00
XI-102	Socket for I-102	MOUNTING BASE: Lumiline disc base	262 0177 00

20V-2 Parts List

ITEM	CIRCUIT FUNCTION	DESCRIPTION	PART NUMBER
XI-103	Socket for I-103	Same as XI-102	
XI-104	Socket for I-104	Same as XI-101	
XK-101	Socket for K-101	SOCKET: tube, octal	220 1005 00
XV-101	Socket for V-101	SOCKET: tube, miniature 7 contact	220 1034 00
XV-102	Socket for V-102	Same as XK-101	
XV-103	Socket for V-103	SOCKET: tube, 5 contact	220 5520 00
XV-104	Socket for V-104	SOCKET: tube, 5 contact giant	220 1016 00
XV-105	Socket for V-105	Same as XV-104	
XV-106	Socket for V-106	Same as XK-101	
XV-107	Socket for V-107	Same as XK-101	
XV-108	Socket for V-108	Same as XV-104	
XV-109	Socket for V-109	Same as XV-104	
XV-110	Socket for V-110	SOCKET: tube, octal	220 1059 00
XV-111	Socket for V-111	SOCKET: tube, 4 contact	220 5420 00
XV-112	Socket for V-112	Same as XV-111	
XV-113	Socket for V-113	SOCKET: tube, 4 contact	220 5410 00
XV-114	Socket for V-114	Same as XV-113	
XT-101	Socket for T-101	SOCKET: tube, 7 contact	220 1790 00
XT-102	Socket for T-102	Same as XT-101	
XT-103	Socket for T-103	Same as XT-101	
XY-101	Socket for Y-101	Same as XK-101	
XY-102	Socket for Y-102	Same as XK-101	

**SECTION 6
ILLUSTRATIONS**

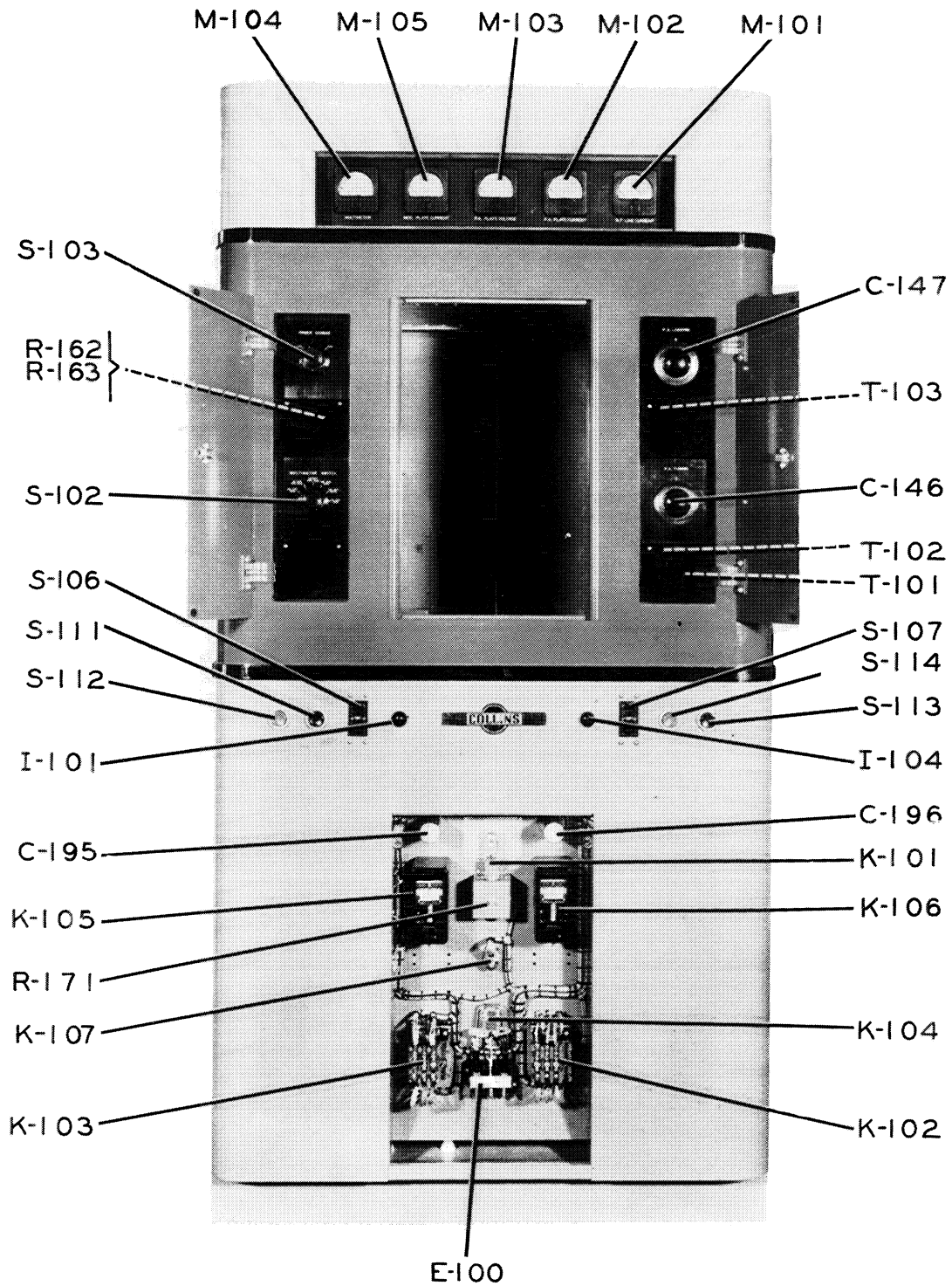

Figure 6-1. Transmitter Parts Arrangement, Front View

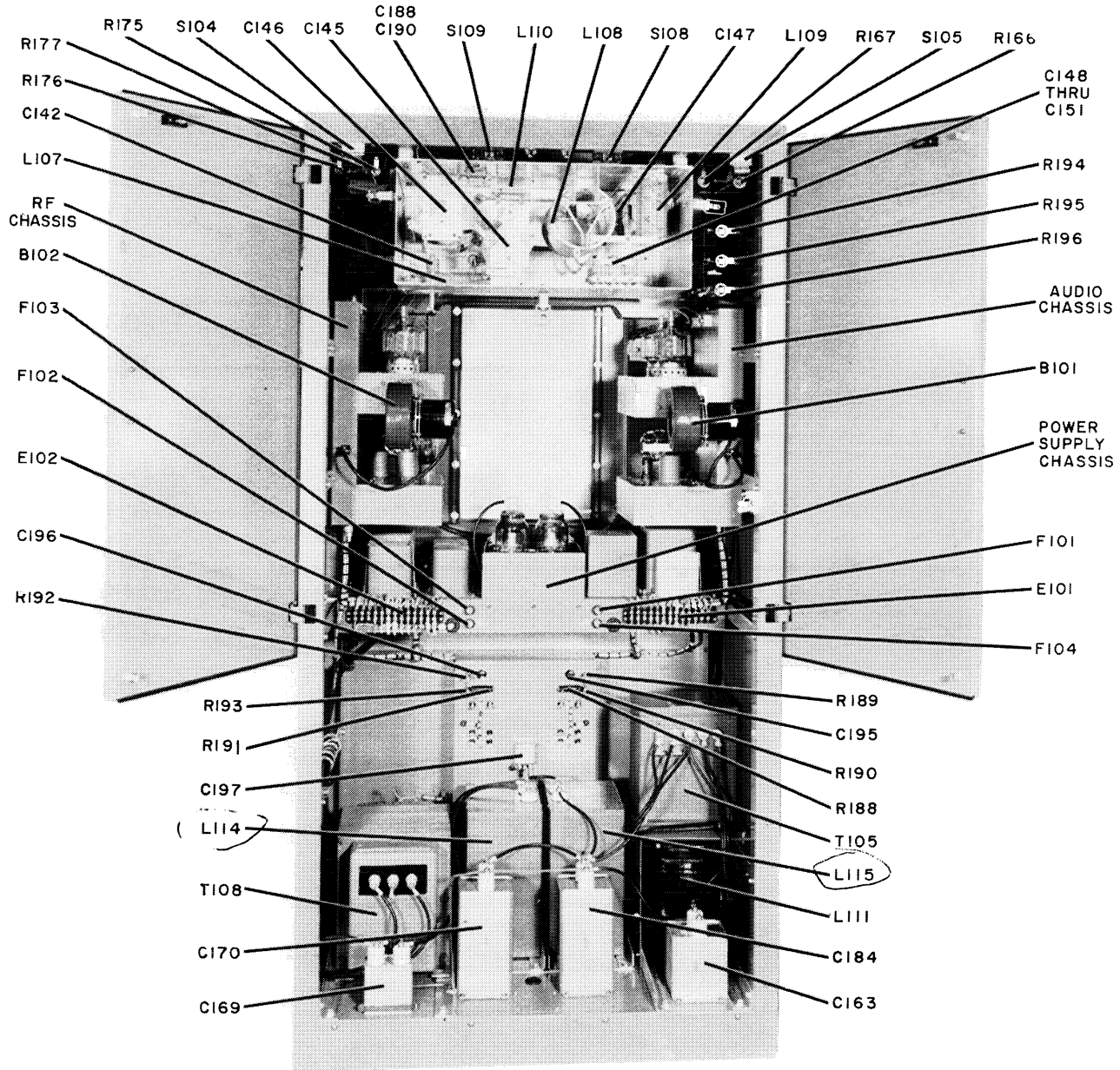

Figure 6-2. Transmitter Parts Arrangement, Rear View

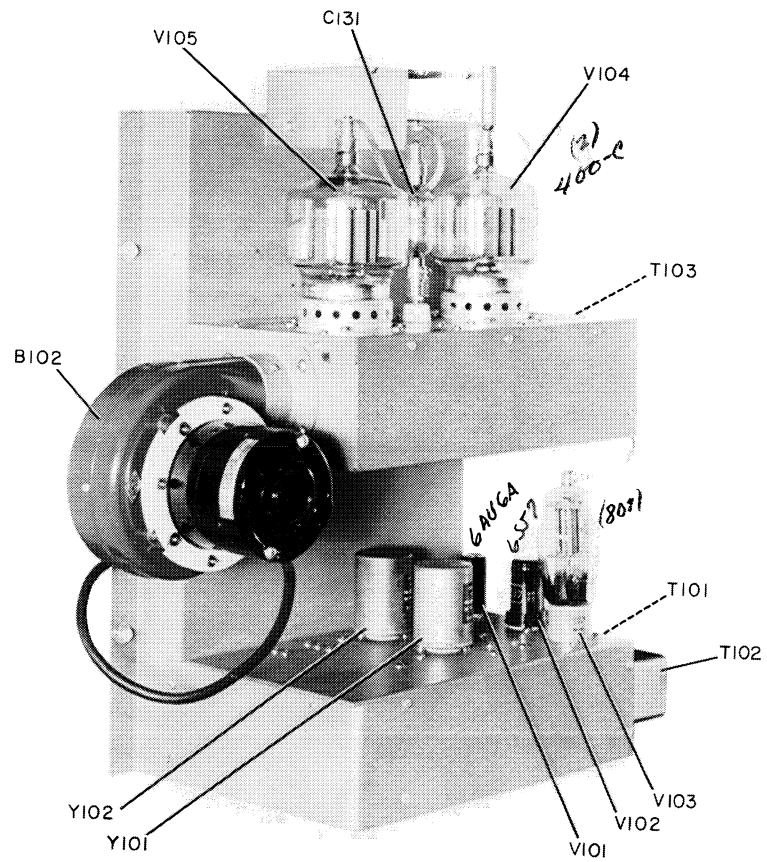

Figure 6-3. R-F Chassis Parts Arrangement

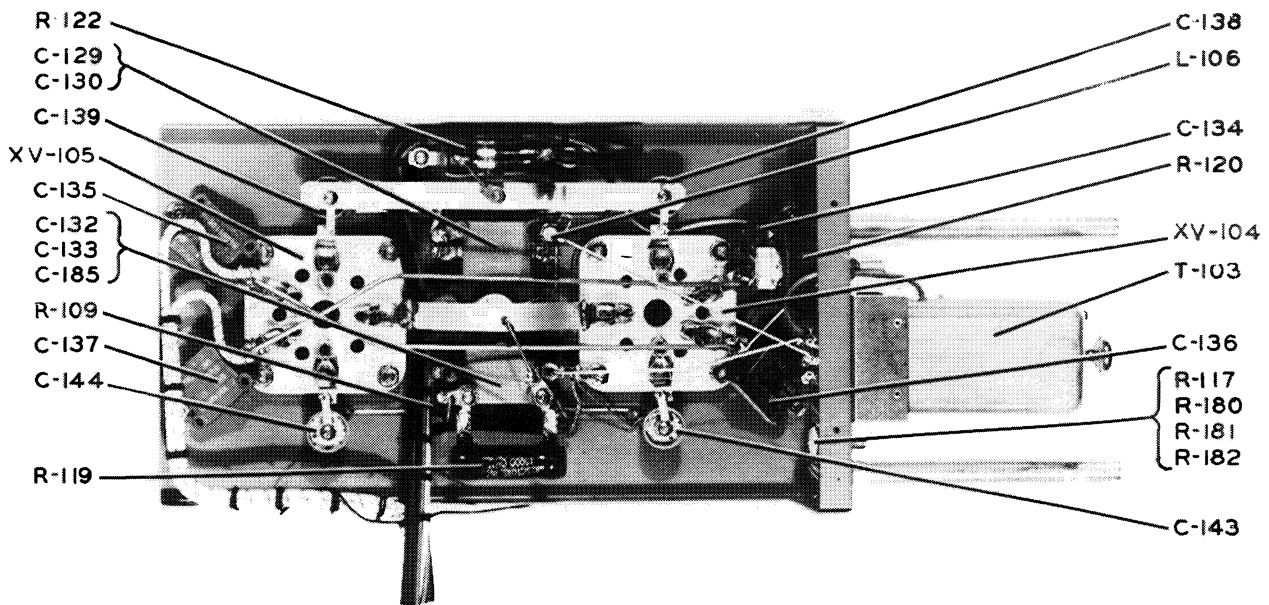
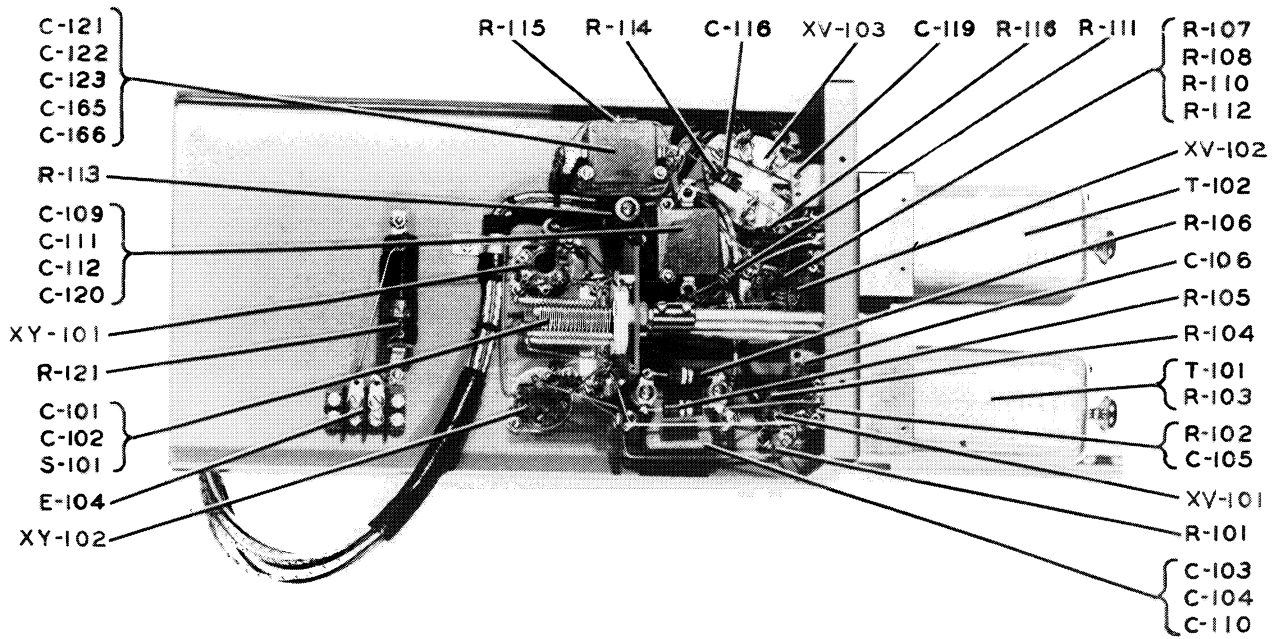

Figure 6-4. R-F Chassis Parts Arrangement, Bottom View

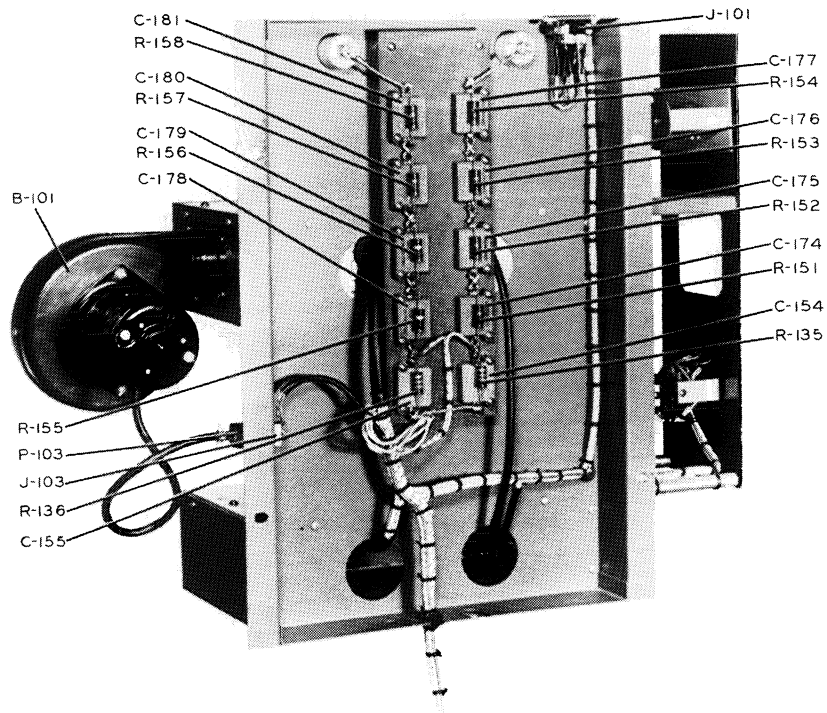
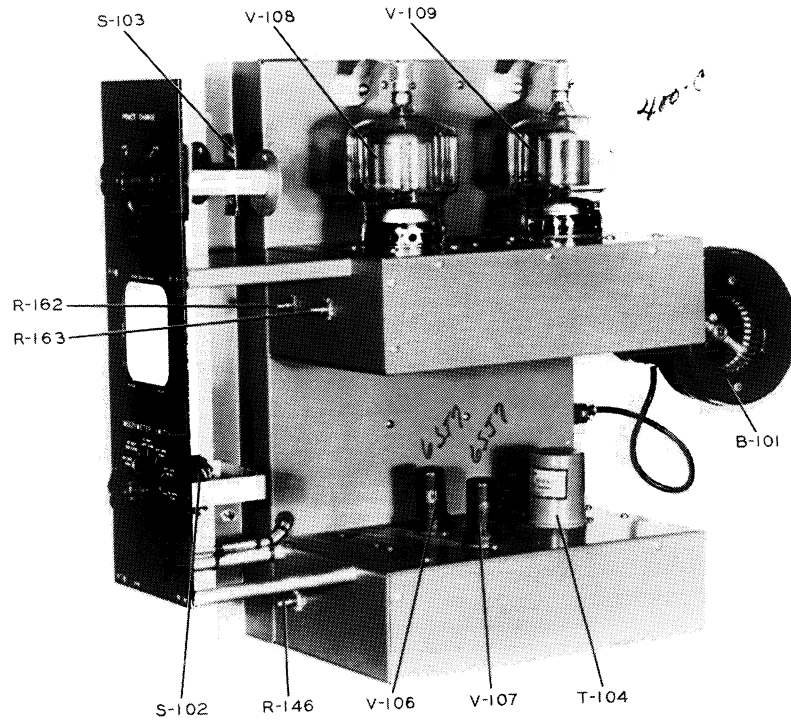

Figure 6-5. Audio Chassis Parts Arrangement

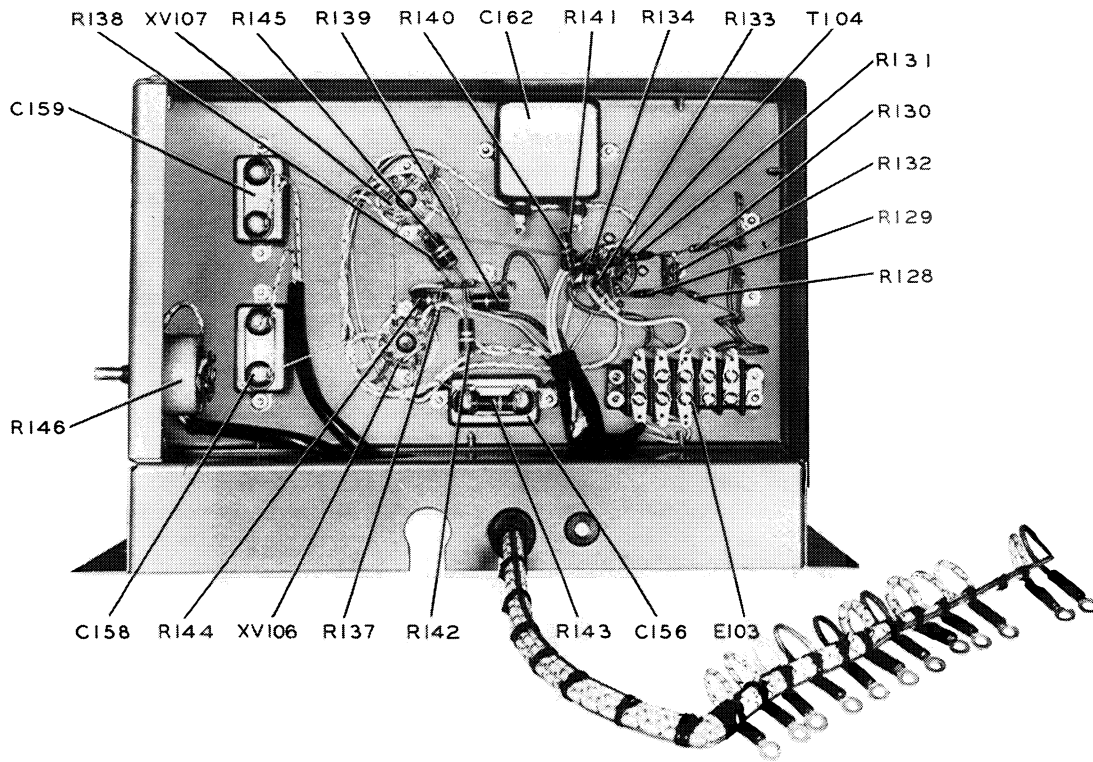
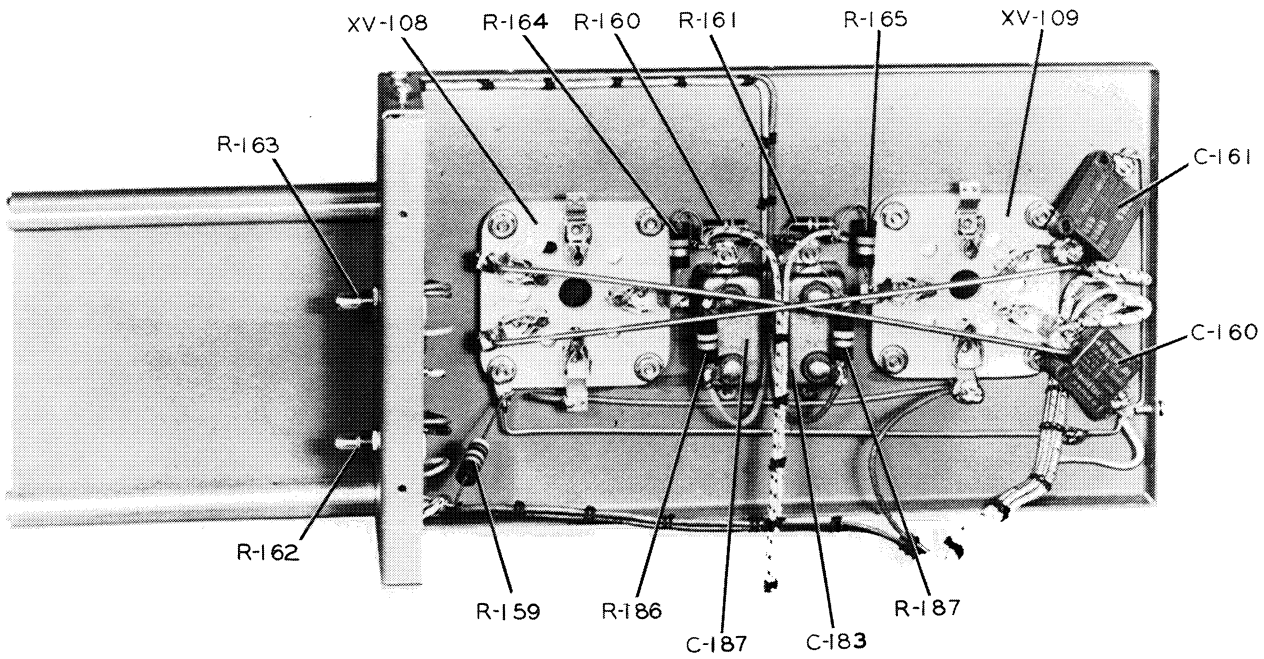

Figure 6-6. Audio Chassis Parts Arrangement, Bottom View

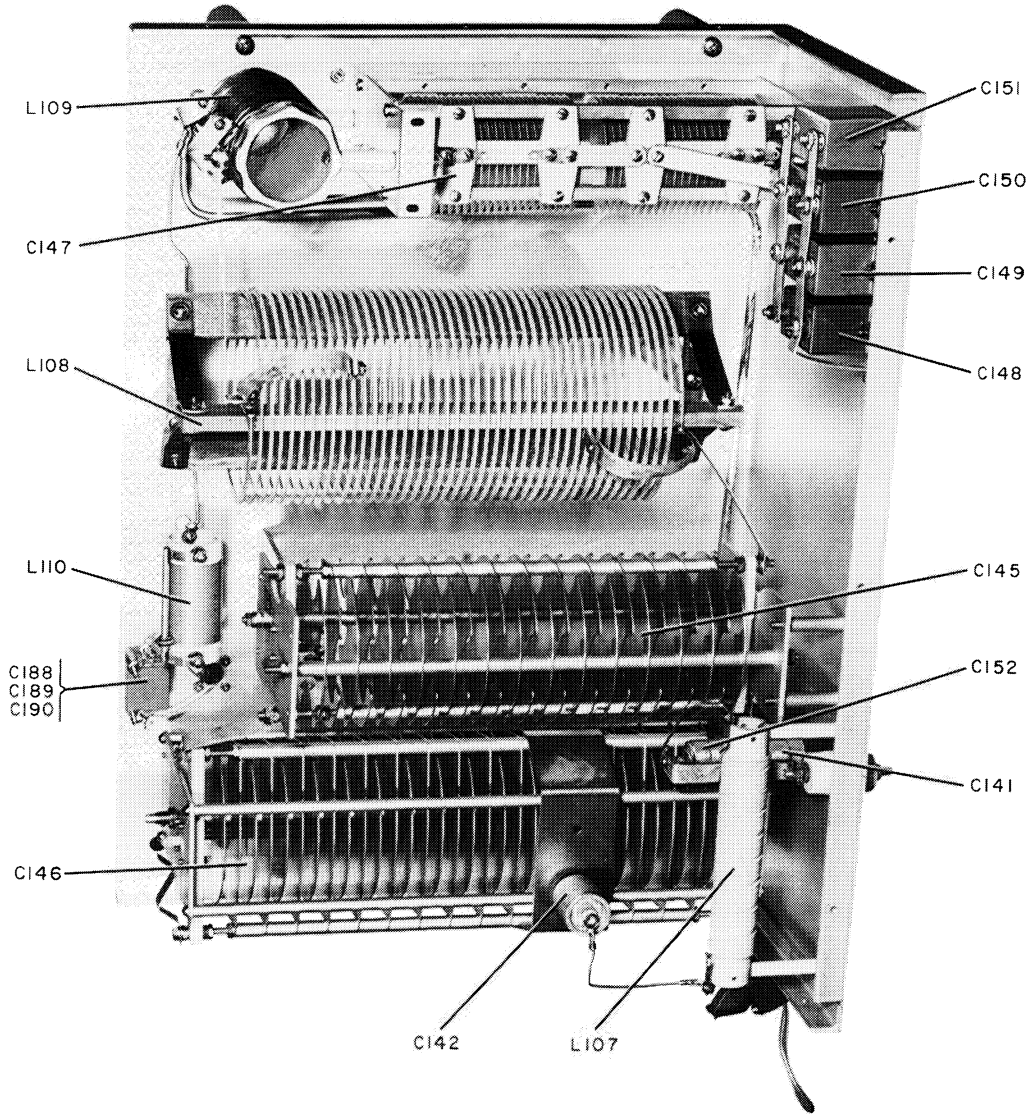

Figure 6-7. Output Network Parts Arrangement, Bottom View

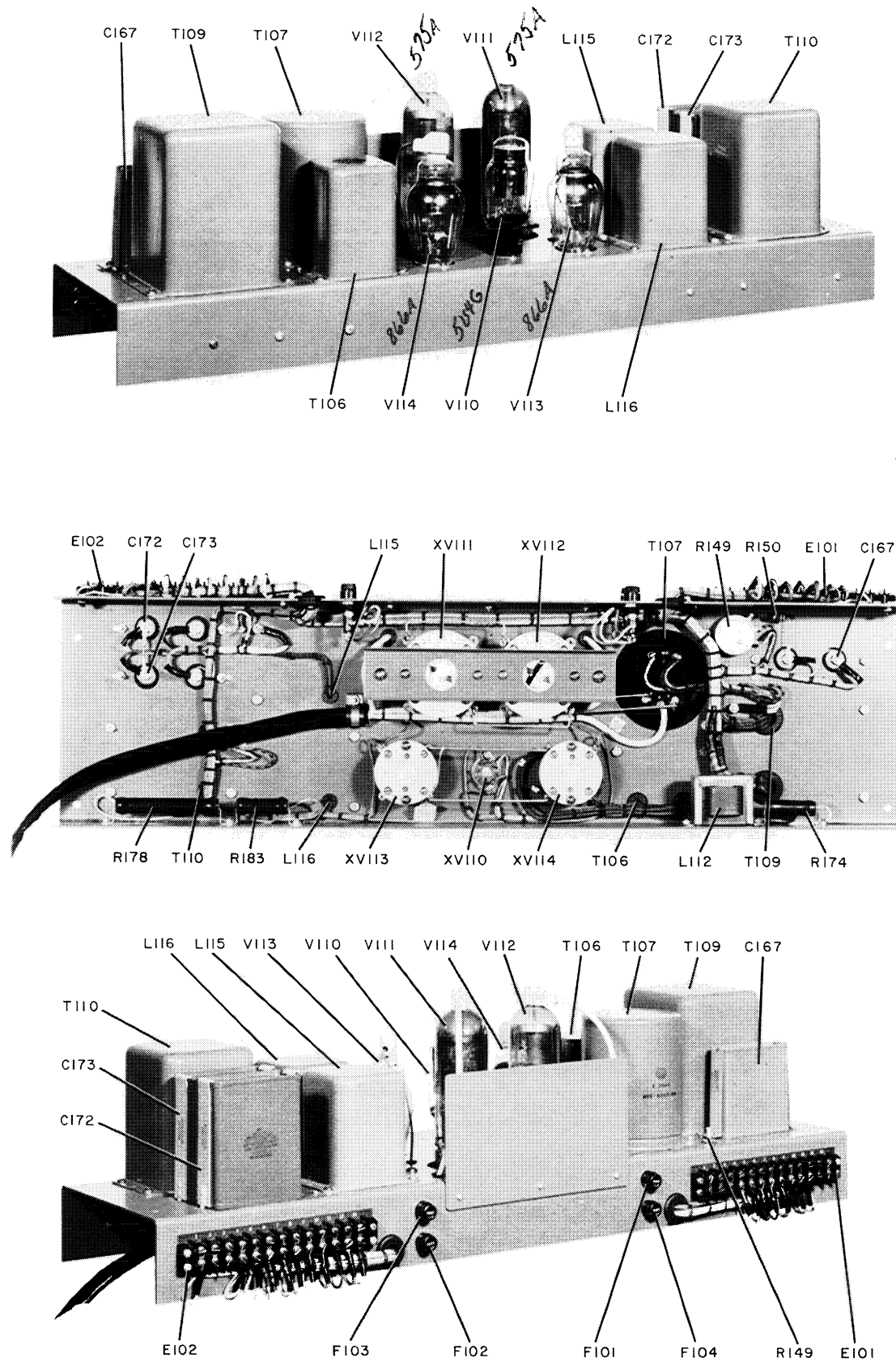

Figure 6-8. Power Supply Chassis Parts Arrangement

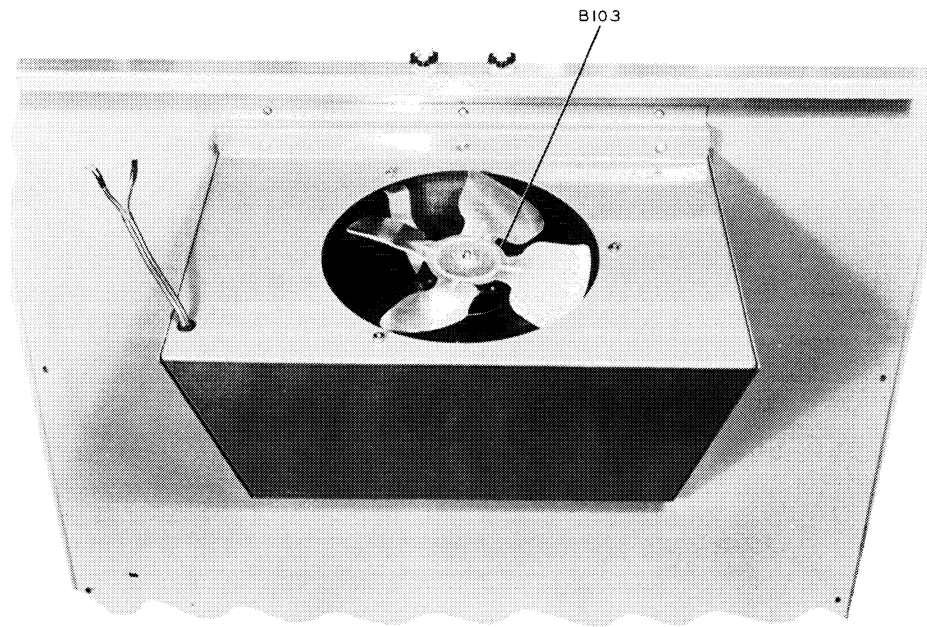

Figure 6-9. Rear Panel Parts Arrangement

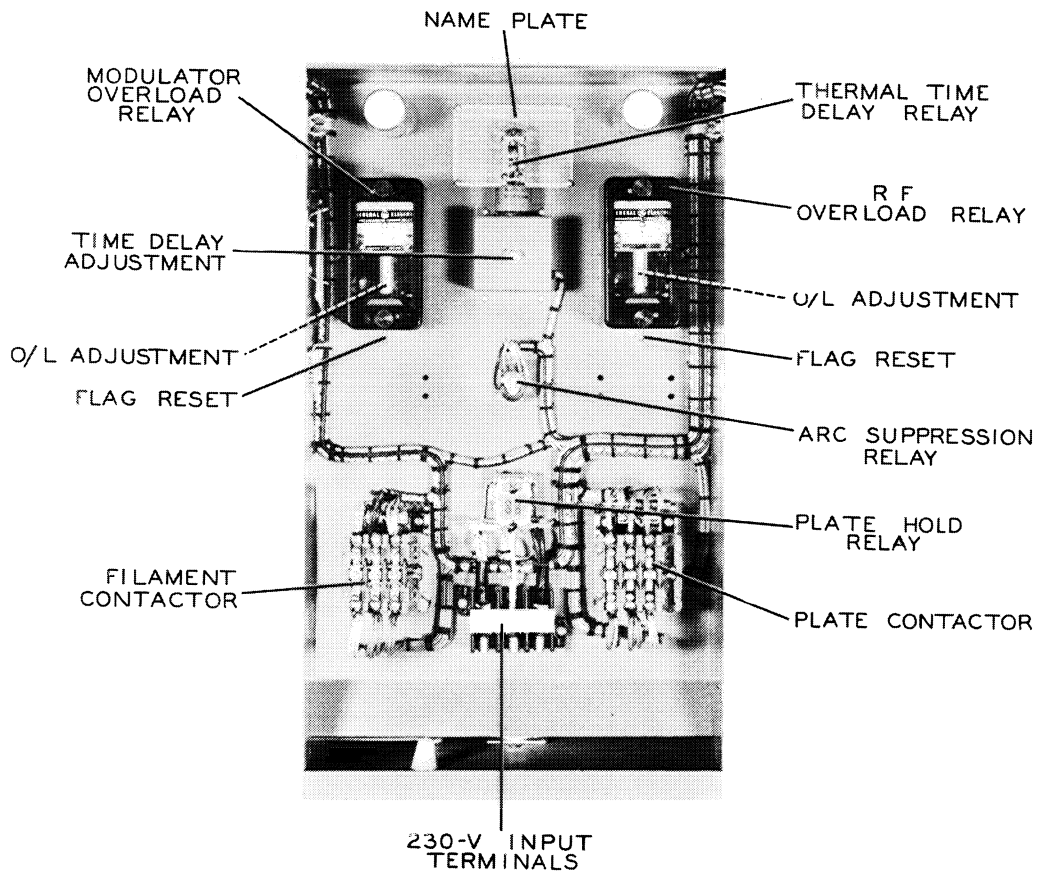

Figure 6-10. Relay Panel Controls

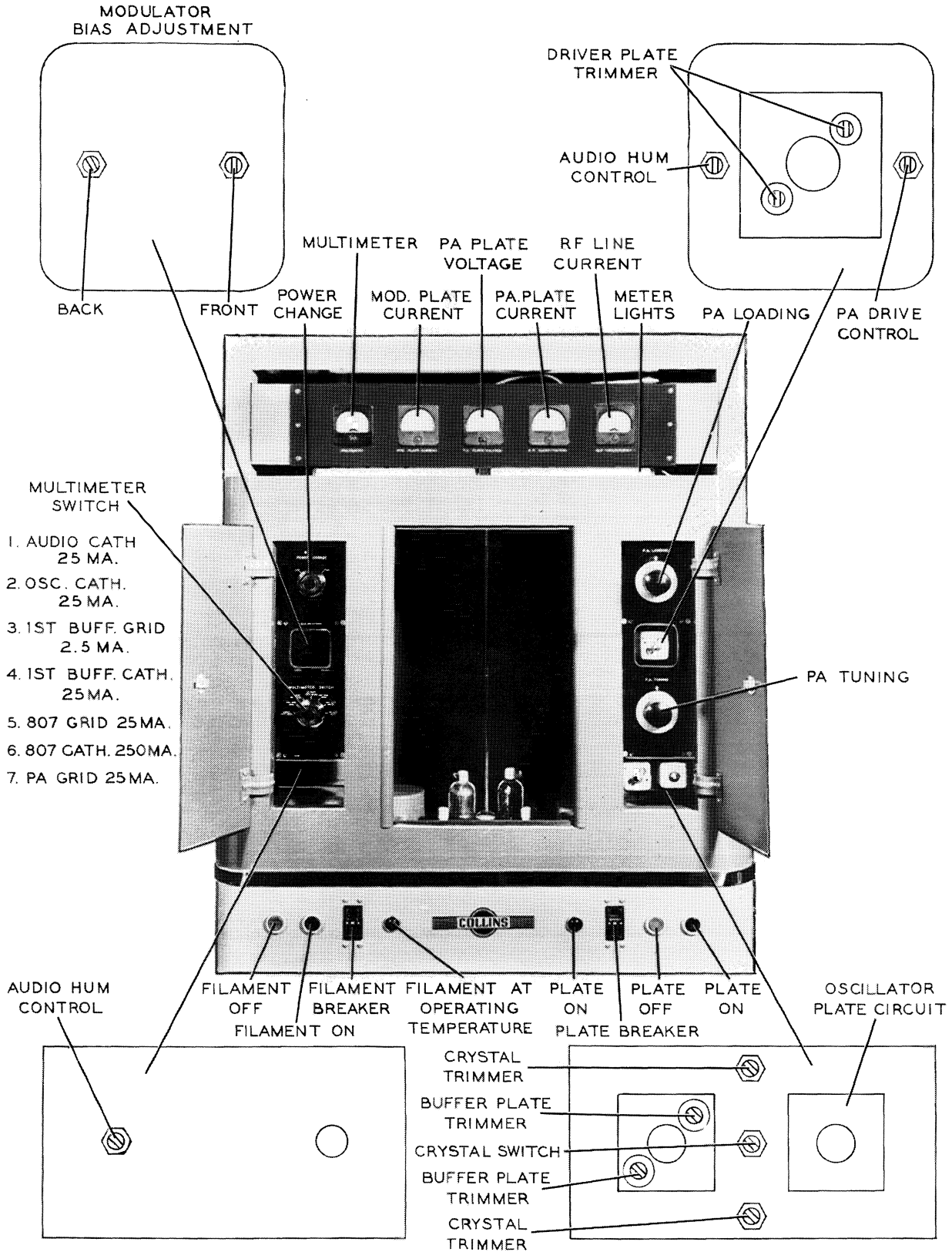

Figure 6-11. Location of Controls and Instruments

SECTION 7 LINE DRAWINGS

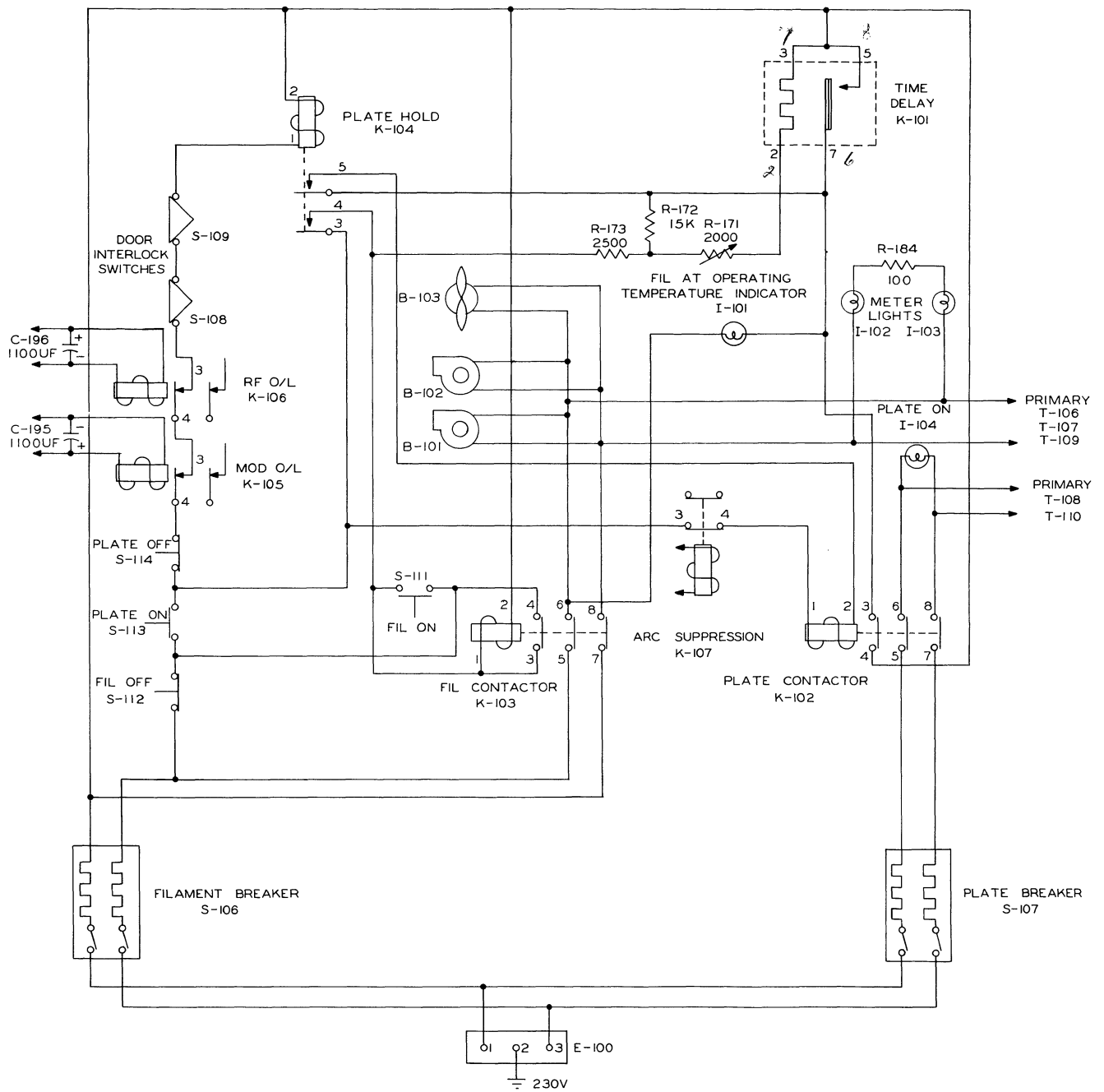

Figure 7-1. Primary Control Circuit Simplified Schematic

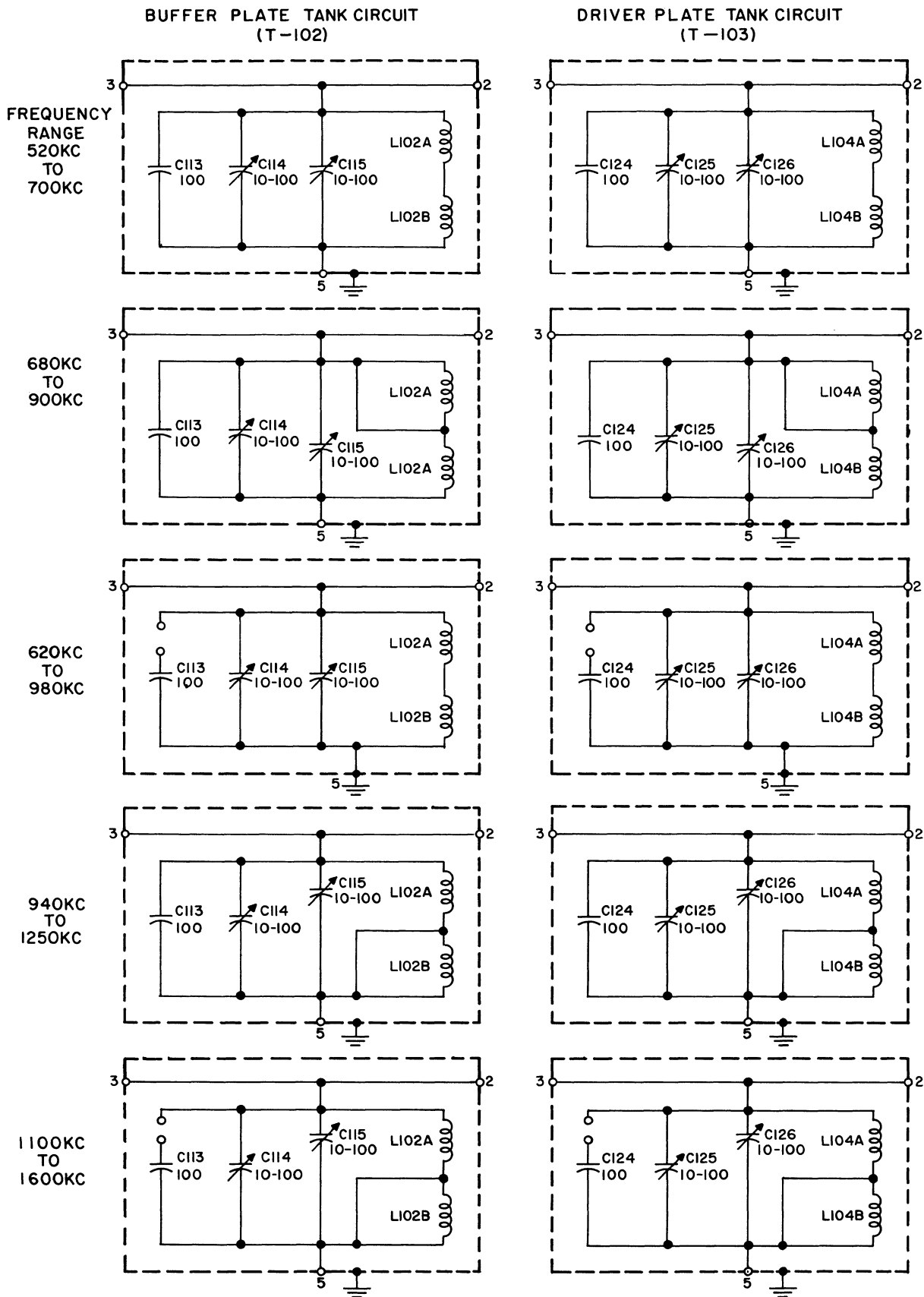
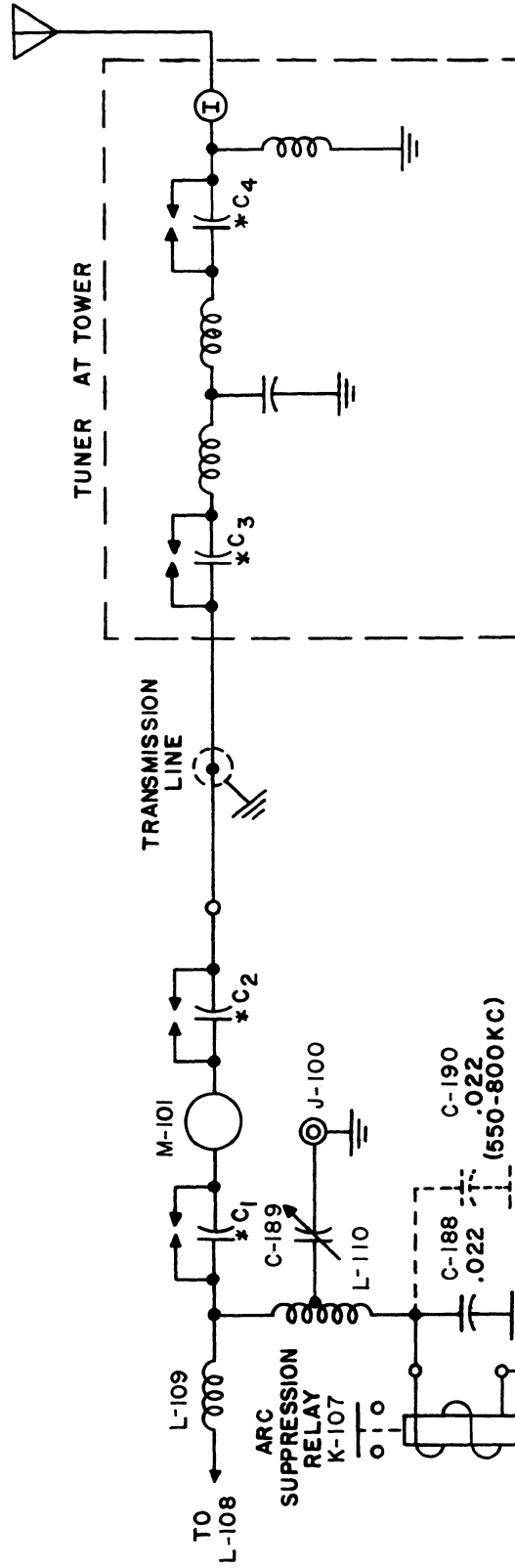

Figure 7-2. T-102 and T-103 Internal Connections



* C₁, C₂, C₃, C₄ - POSITIONS AT WHICH C-192/C-193 AND SPARK GAP CAN BE INSERTED. USE ONE POSITION AND JUMPER ACROSS OTHERS. C-192/C-193 ARE .0111 F EACH. TRANSMITTER USUALLY SHIPPED WITH C-192/C-193 AT C₂.

Figure 7-3. Arc-Suppression Circuit Simplified Schematic

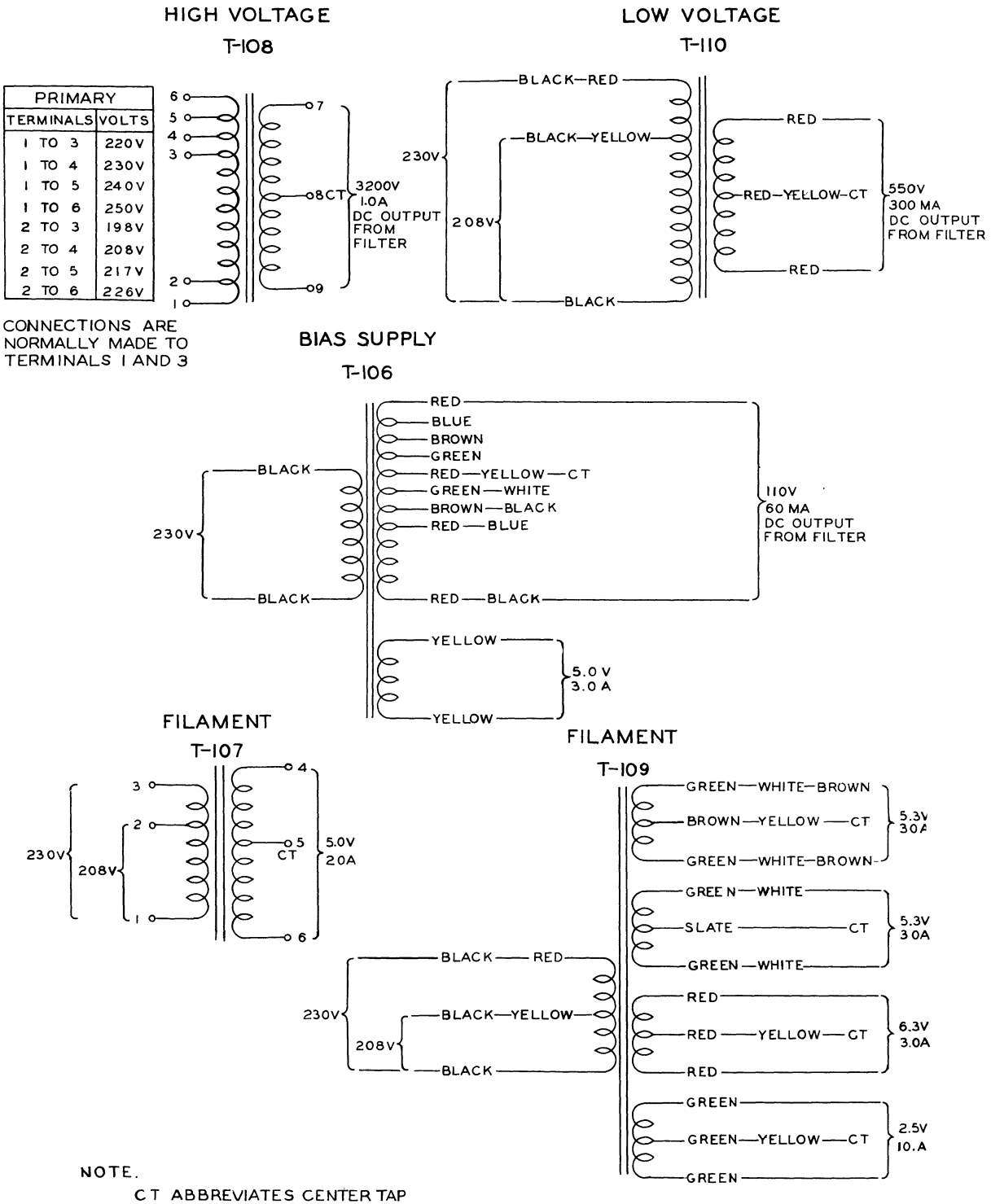
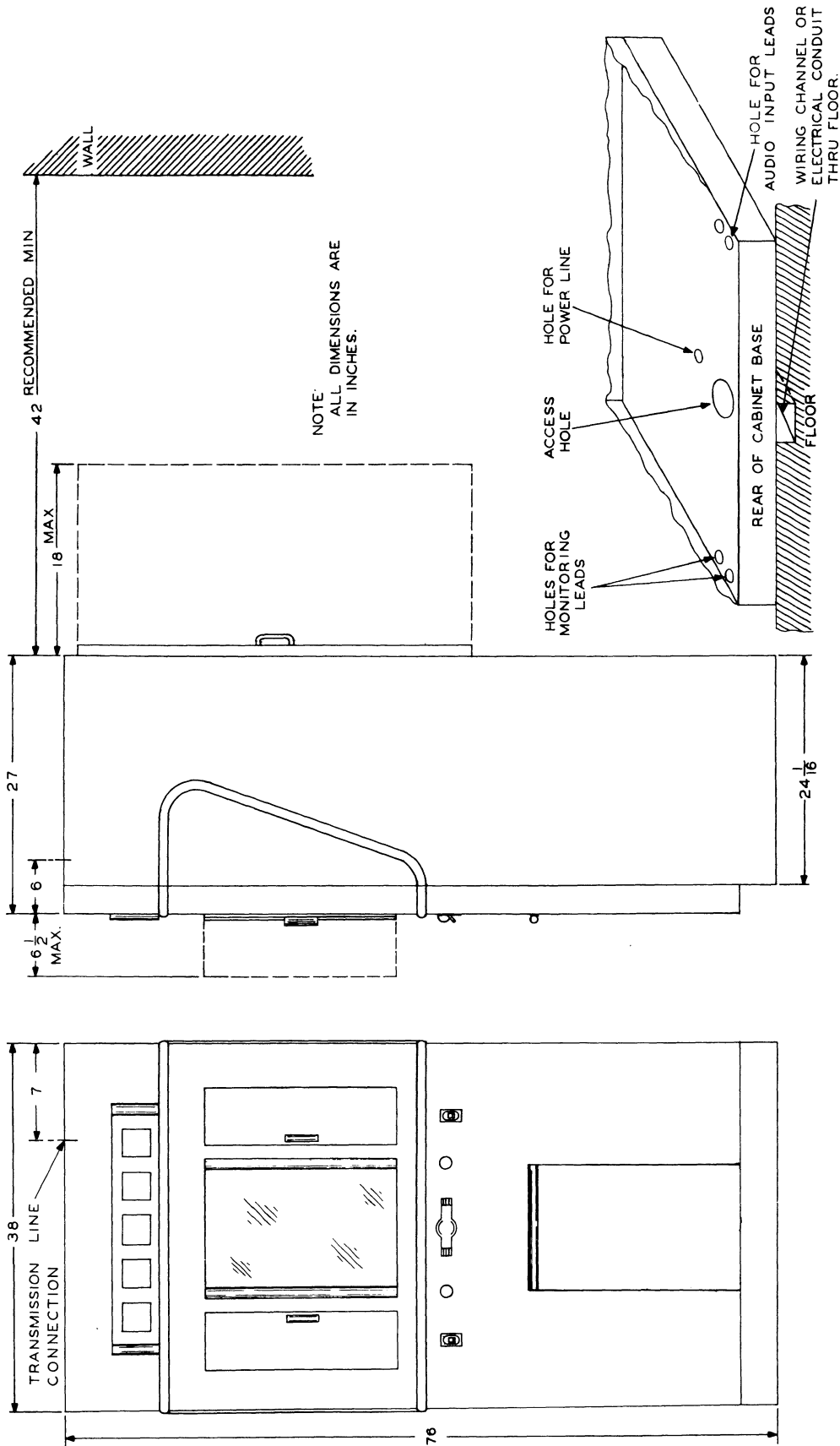
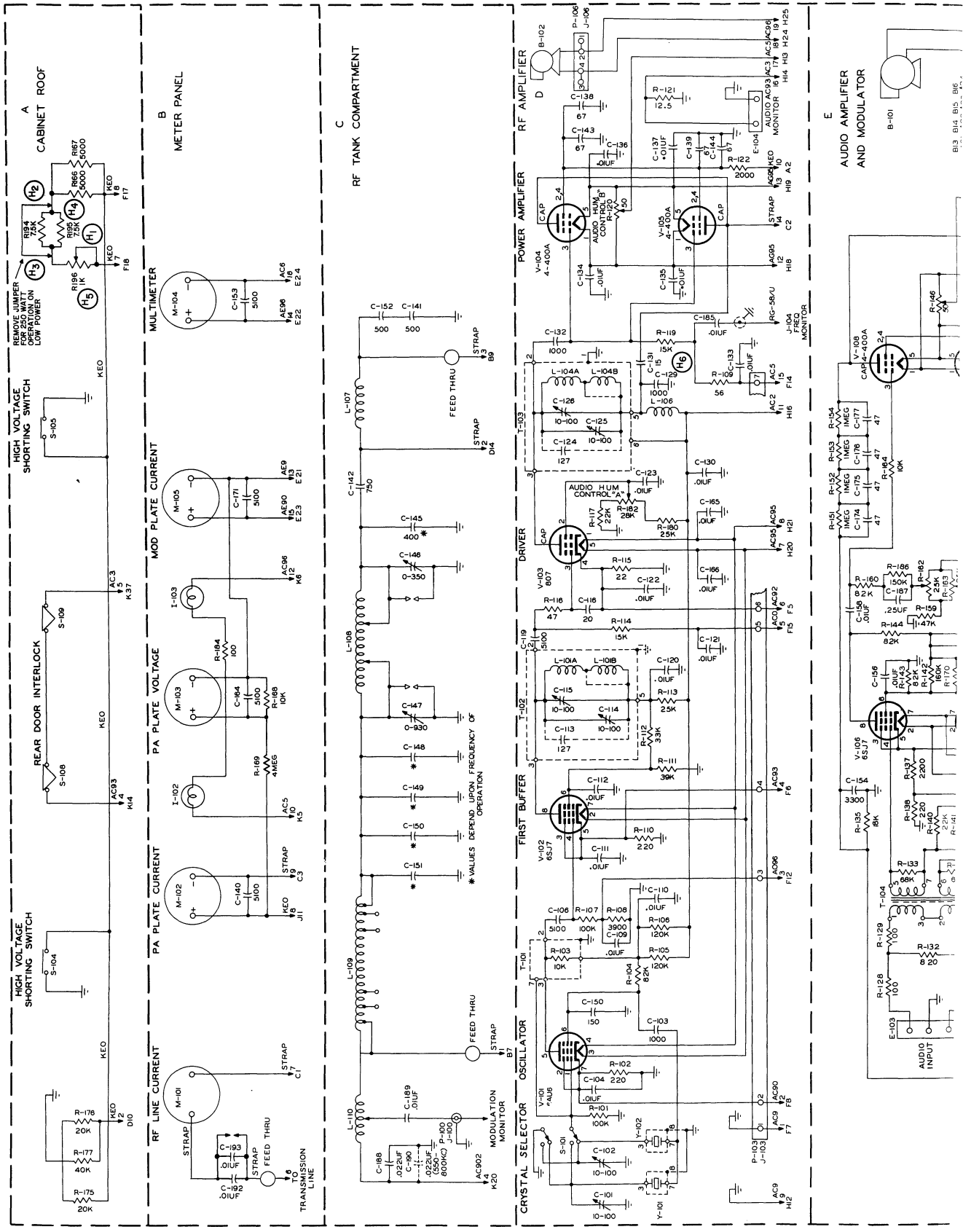

Figure 7-4. Transformer Details



CONNECTION	RECOMMENDED WIRE	WIRE SIZES
STATION POWER LINE SWITCH TO TRANSMITTER INPUT (208/230V SINGLE PHASE 50/60 CPS SOURCE FUSED AT WALL CUT OUT BOX FOR 30 AMPERES)	TWO NO. 6 WIRES	ONE RG-8/U COAXIAL CABLE
GROUND FEED (FURTHER BONDING OF CABINET TO BUILDING GROUND WOULD BE DESIRABLE)	ONE NO. 4 BARE WIRE	ONE 2 WIRE SHIELDED LEAD
FREQUENCY MONITOR FEED	ONE RG-8/U COAXIAL CABLE	7/8" RIGID 50 OR 72 OHM COAXIAL CABLE
MODULATION MONITOR FEED	ONE RG-8/U COAXIAL CABLE	ONE 2 WIRE SHIELDED LEAD
AUDIO MONITOR FEED	ONE 2 WIRE SHIELDED LEAD	ONE 2 WIRE SHIELDED LEAD
AUDIO INPUT LEAD	ONE 2 WIRE SHIELDED LEAD	ONE 2 WIRE SHIELDED LEAD
TRANSMISSION LINE	7/8" RIGID 50 OR 72 OHM COAXIAL CABLE	7/8" RIGID 50 OR 72 OHM COAXIAL CABLE

Figure 7-5. Typical Installation Diagram



A
CABINET ROOF

B
METER PANEL

C
RF TANK COMPARTMENT

D
POWER AMPLIFIER

E
AUDIO AMPLIFIER AND MODULATOR

REMOVE JUMPER FOR 250 WATT IN LOW POWER

* VALUES DEPEND UPON FREQUENCY OF OPERATION

L107

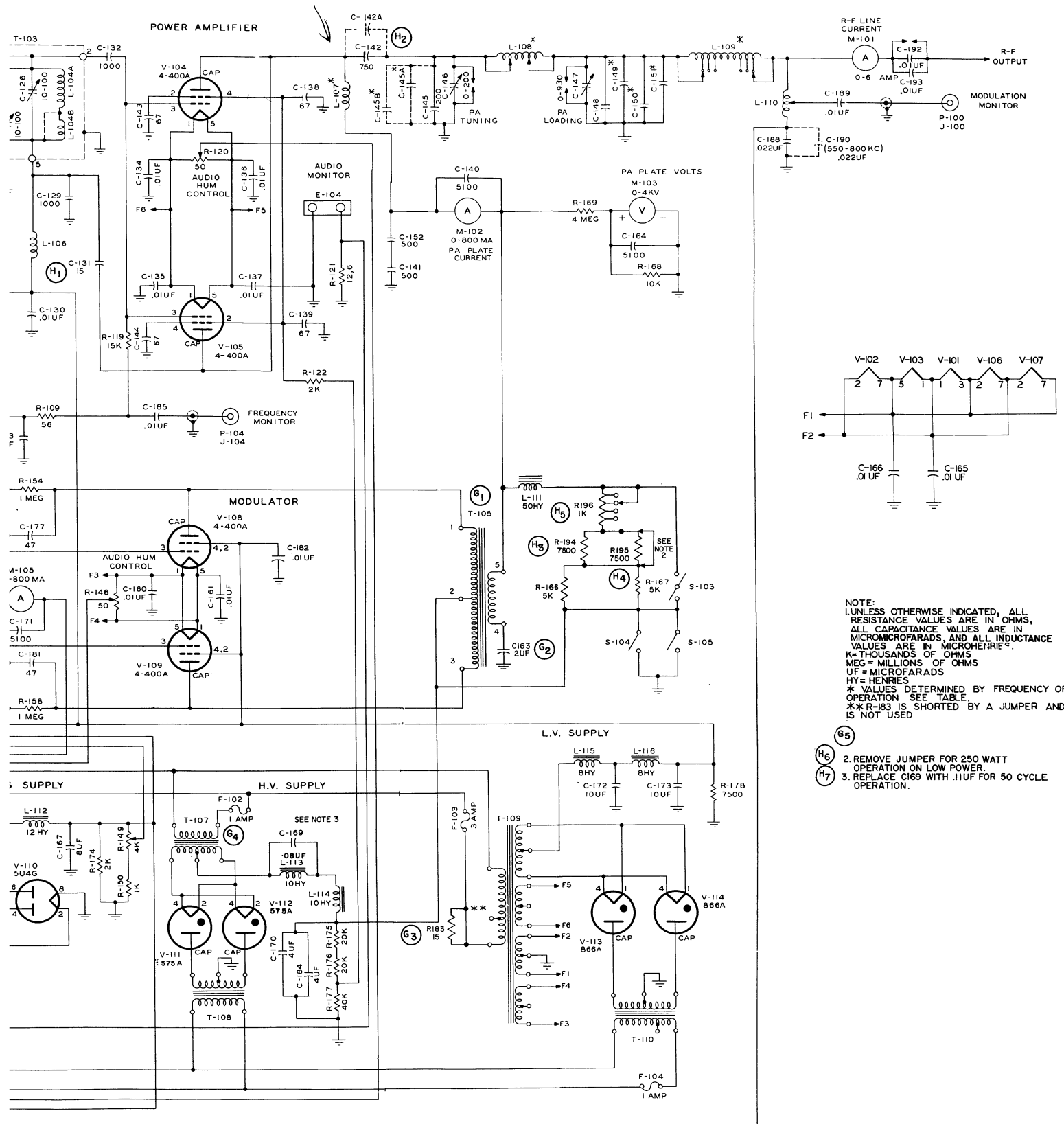

NOTE:
 1. UNLESS OTHERWISE INDICATED, ALL RESISTANCE VALUES ARE IN OHMS, ALL CAPACITANCE VALUES ARE IN MICROMICROFARADS, AND ALL INDUCTANCE VALUES ARE IN MICROHENRIES.
 K= THOUSANDS OF OHMS
 M= MILLIONS OF OHMS
 UF= MICROFARADS
 HY= HENRIES
 * VALUES DETERMINED BY FREQUENCY OF OPERATION SEE TABLE.
 ** R-183 IS SHORTED BY A JUMPER AND IS NOT USED

- (G5)
- (H6) 2. REMOVE JUMPER FOR 250 WATT OPERATION ON LOW POWER.
- (H7) 3. REPLACE C169 WITH .11UF FOR 50 CYCLE OPERATION.

Figure 7-7. Main Schematic

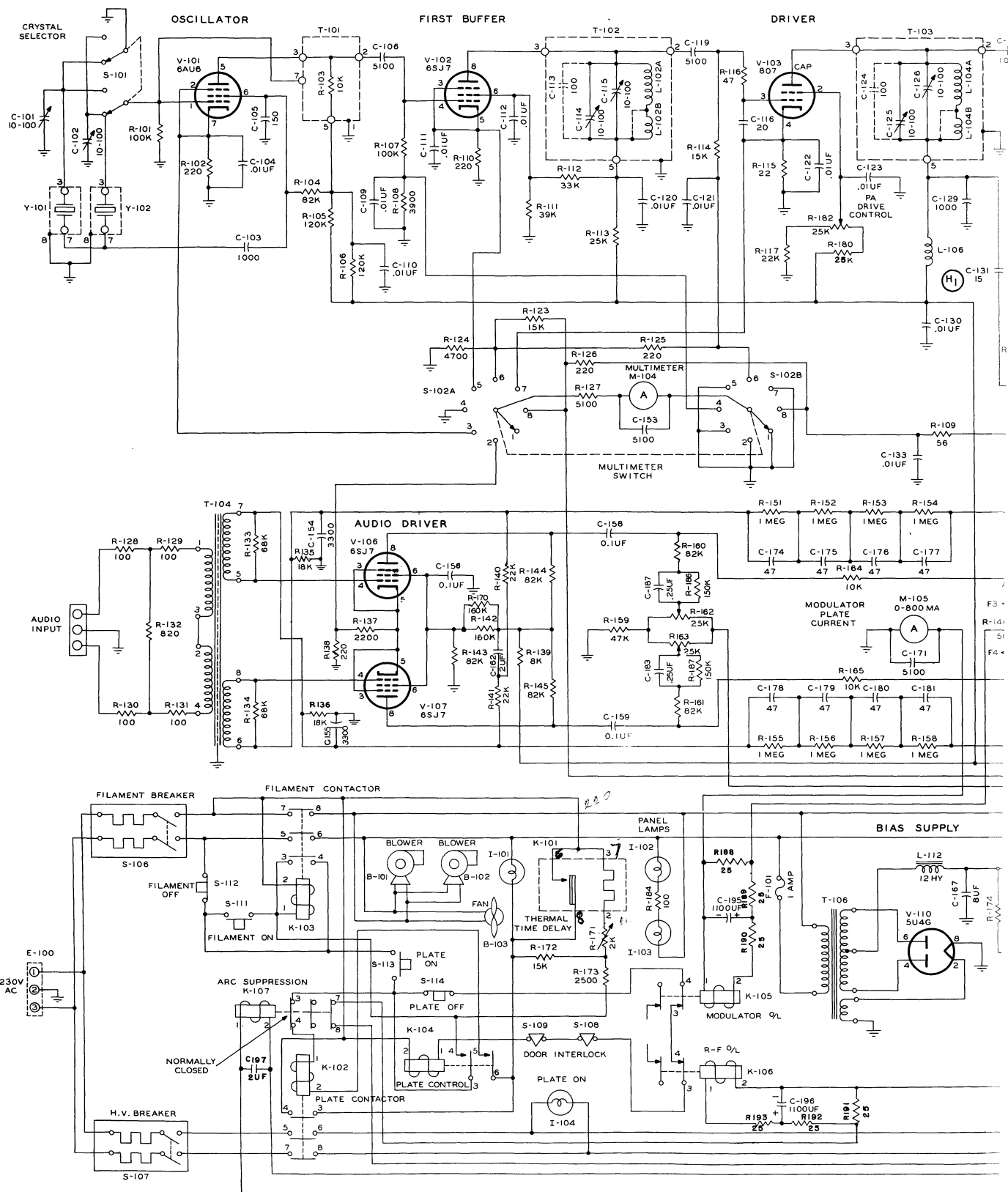

ELECTRICAL WIRE CODE

EXAMPLES

UNSHIELDED WIRE, MIL TYPE B #22 AWG, WHITE WITH RED AND GREEN TRACERS:

 D
Type of Wire
 A
Size of Wire
 9
Color of Body
 25
Color of Tracers
—
 4-1/4
Length of Wire in Inches
(Includes Stripping & Tinning)

SHIELDED WIRE (SINGLE), MIL TYPE C, #15 AWG, WHITE WITH RED AND GREEN TRACERS:

 R
Type of Wire
 D
Size of Wire
 S
Shielded
 9
Color of Body
 25
Color of Tracers
—
 4-1/4
Length of Wire in Inches
(Includes Stripping & Tinning)

SHIELDED WIRE (MULTIPLE), MIL TYPE B, #22 AWG, WHITE, AND WHITE WITH RED TRACER:

 D
Type of Wire
 A
Size of Wire
 S
Shielded
 (9)
First Conductor
 (92)
Second Conductor
—
 4-1/4
Length of Wire in Inches
(Includes Stripping & Tinning)

TYPE OF WIRE CODE			SIZE OF WIRE CODE		COLOR CODE	
LETTER	TYPE OF WIRE	FAMILY USUALLY FOUND IN	LETTER	SIZE	NUMBER OR LETTER	COLOR
A	Cotton Braid Over Plastic (Formerly AN-J-C-48)	440 Plain 443 Shielded	A	#22 AWG	0	Black
B	Busbar, Round Tinned	421	B	#20	1	Brown
C	MIL-W-16878 Type B (#20 and Larger) (600 Volts)	439	C	#18	2	Red
D	Miniature Wire, MIL-W-16878 Type B (#22 & Smaller)	439-7000 Series	D	#16	3	Orange
E	Extra Flexible Varnished Cambric	423	E	#14	4	Yellow
F	Extra Flexible Varnished Cambric	423	F	#12	5	Green
G			G	#10	6	Blue
H	Kel-F (Monochlorotrifluoroethylene)	422	H	#8	7	Violet
J			J	#6	8	Gray (Slate)
K	Neon Sign Cable (15,000 Volts)	423 0004 00	K	#4	9	White
L	Silicone	425 0942 00	L	#2	a	Clear
M			M	#1	b	Tan
N	Single Conductor Stranded (Not Rubber Covered)	422	N	#0	c	Pink
P	Single Conductor Stranded (Rubber Covered)	423	P	#00	d	Maroon
Q			Q	#000	e	Light Green
R	MIL-W-16878 Type C (1000 Volts)	439 1000 Series	R	#0000	f	Light Blue
T	Teflon, MIL-W-16878 Type E (600 Volts)	439 4000 Series	T	#28		
V	MIL-W-16878 Type D (3000 Volts)	439 3000 Series	V	#26		
W	Teflon, MIL-W-16878 Type EE (1000 Volts)	439 0000 Series	W	#24		
X			X	#19		
Y			Y	#30		
Z	Acetate Yarn Telephone Type	428	Z			

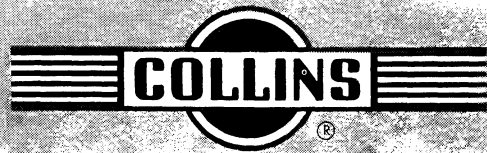

COLLINS RADIO COMPANY